

Version 1.0

Published April 2014

Copyright©2014 ASRock INC. All rights reserved.



Copyright Notice:

No part of this documentation may be reproduced, transcribed, transmitted, or translated in any language, in any form or by any means, except duplication of documentation by the purchaser for backup purpose, without written consent of ASRock Inc.

Products and corporate names appearing in this documentation may or may not be registered trademarks or copyrights of their respective companies, and are used only for identification or explanation and to the owners' benefit, without intent to infringe.

Disclaimer:

Specifications and information contained in this documentation are furnished for informational use only and subject to change without notice, and should not be construed as a commitment by ASRock. ASRock assumes no responsibility for any errors or omissions that may appear in this documentation.

With respect to the contents of this documentation, ASRock does not provide warranty of any kind, either expressed or implied, including but not limited to the implied warranties or conditions of merchantability or fitness for a particular purpose.

In no event shall ASRock, its directors, officers, employees, or agents be liable for any indirect, special, incidental, or consequential damages (including damages for loss of profits, loss of business, loss of data, interruption of business and the like), even if ASRock has been advised of the possibility of such damages arising from any defect or error in the documentation or product.

The terms HDMI™ and HDMI High-Definition Multimedia Interface, and the HDMI logo are trademarks or registered trademarks of HDMI Licensing LLC in the United States and other countries.



This device complies with Part 15 of the FCC Rules. Operation is subject to the following two conditions:

- (1) this device may not cause harmful interference, and
- (2) this device must accept any interference received, including interference that may cause undesired operation.

CALIFORNIA, USA ONLY

The Lithium battery adopted on this motherboard contains Perchlorate, a toxic substance controlled in Perchlorate Best Management Practices (BMP) regulations passed by the California Legislature. When you discard the Lithium battery in California, USA, please follow the related regulations in advance.

“Perchlorate Material-special handling may apply, see www.dtsc.ca.gov/hazardouswaste/perchlorate”

ASRock Website: <http://www.asrock.com>

Motherboard Layout

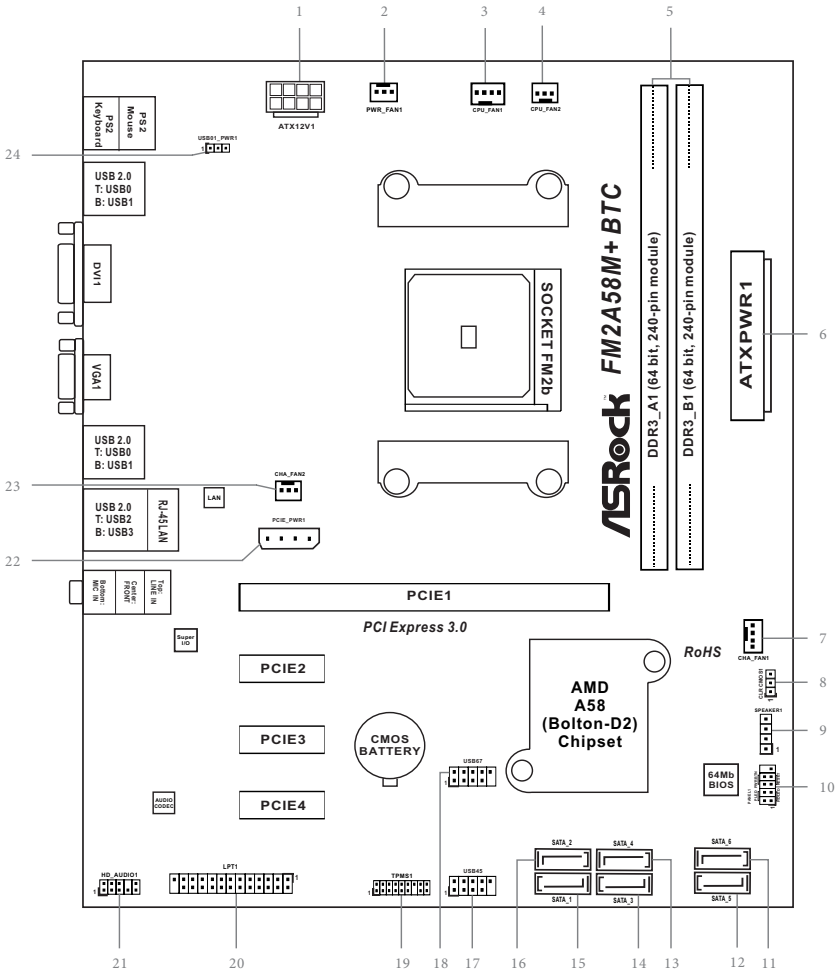

English

No.	Description
1	ATX 12V Power Connector (ATX12V1)
2	Power Fan Connector (PWR_FAN1)
3	CPU Fan Connector (CPU_FAN1)
4	CPU Fan Connector (CPU_FAN2)
5	2 x 240-pin DDR3 DIMM Slots (DDR3_A1, DDR3_B1)
6	ATX Power Connector (ATXPWR1)
7	Chassis Fan Connector (CHA_FAN1)
8	Clear CMOS Jumper (CLRCMOS1)
9	Chassis Speaker Header (SPEAKER1)
10	System Panel Header (PANEL1)
11	SATA2 Connectors (SATA_6)
12	SATA2 Connectors (SATA_5)
13	SATA2 Connectors (SATA_4)
14	SATA2 Connectors (SATA_3)
15	SATA2 Connectors (SATA_1)
16	SATA2 Connectors (SATA_2)
17	USB 2.0 Header (USB45)
18	USB 2.0 Header (USB67)
19	TPM Header (TPMS1)
20	Print Port Header (LPT1)
21	Front Panel Audio Header (HD_AUDIO1)
22	PCIe Power Connector (PCIE_PWR1)
23	Chassis Fan Connector (CHA_FAN2)
24	USB Power Jumper (USB01_PWR1)

I/O Panel

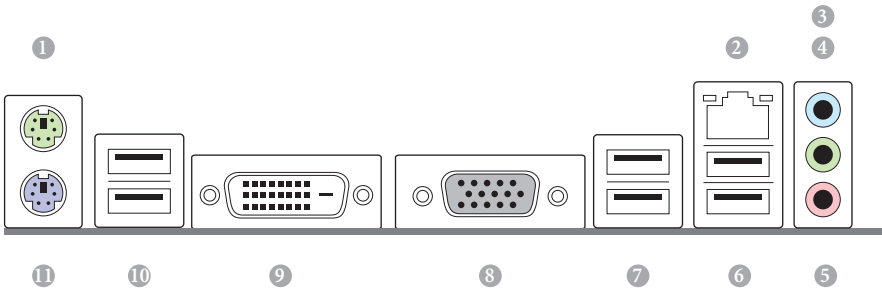

No.	Description	No.	Description
1	PS/2 Mouse Port (Green)	7	USB 2.0 Ports (USB23)
2	LAN RJ-45 Port*	8	D-Sub Port (VGA1)
3	Line In (Light Blue)	9	DVI-D Port (DVI1)
4	Front Speaker (Lime)	10	USB 2.0 Ports (USB01)
5	Microphone (Pink)	11	PS/2 Keyboard Port (Purple)
6	USB 2.0 Ports (USB45)		

* There are two LEDs on the LAN port. Please refer to the table below for the LAN port LED indications.

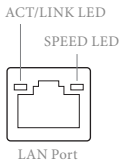

Activity / Link LED		Speed LED	
Status	Description	Status	Description
Off	No Link	Off	10Mbps connection
Blinking	Data Activity	Orange	100Mbps connection
On	Link	Green	1Gbps connection

1. Introduction

Thank you for purchasing ASRock **FM2A58M+ BTC** motherboard, a reliable motherboard produced under ASRock's consistently stringent quality control. It delivers excellent performance with robust design conforming to ASRock's commitment to quality and endurance.



Because the motherboard specifications and the BIOS software might be updated, the content of this manual will be subject to change without notice. In case any modifications of this manual occur, the updated version will be available on ASRock website without further notice. You may find the latest VGA cards and CPU support lists on ASRock website as well. ASRock website <http://www.asrock.com>

If you require technical support related to this motherboard, please visit our website for specific information about the model you are using. www.asrock.com/support/index.asp

1.1 Package Contents

ASRock **FM2A58M+ BTC** Motherboard (ATX Form Factor)

ASRock **FM2A58M+ BTC** Quick Installation Guide

ASRock **FM2A58M+ BTC** Support CD

2 x Serial ATA (SATA) Data Cables (Optional)

1 x I/O Panel Shield

1.2 Specifications

- Platform**
- Micro ATX Form Factor
 - All Solid Capacitor design
 - High Density Glass Fabric PCB

- CPU**
- Supports Socket FM2+ 95W / FM2 100W processors
 - 4 + 2 Power Phase design

- Chipset**
- AMD A58 FCH (Bolton-D2)

- Memory**
- Dual Channel DDR3 Memory Technology
 - 2 x DDR3 DIMM Slots
 - Supports DDR3 1866/1600/1333/1066 non-ECC, unbuffered memory (**see CAUTION 1**)
 - Max. capacity of system memory: 32GB (**see CAUTION 2**)
 - Supports Intel® Extreme Memory Profile (XMP) 1.3 / 1.2
 - Supports AMD Memory Profile Technology (AMP)
 - 15µ Gold Contact in DIMM Slots

- Expansion Slot**
- 1 x PCI Express 3.0 x16 Slot (PCIe1 @ x16 mode)
 - * PCIe 3.0 is only supported with FM2+ CPU. With FM2 CPU, it only supports PCIe 2.0.
 - 3 x PCI Express 2.0 x1 Slots
 - 15µ Gold Contact in VGA PCIe Slot (PCIe1)

- Graphics**
- Integrated AMD Radeon™ R7/R5 Series Graphics in A-series APU
 - DirectX 11.1, Pixel Shader 5.0 with FM2+ CPU. DirectX 11, Pixel Shader 5.0 with FM2 CPU.
 - Max. shared memory 2GB
 - Dual VGA output: support DVI-D and D-Sub by independent display controllers
 - Supports Dual-link DVI-D with max. resolution up to 2560x1600 @ 60Hz

- Supports D-Sub with max. resolution up to 1920x1200 @ 60Hz
- Supports AMD Steady Video™ 2.0: New video post processing capability for automatic jitter reduction on home/online video
- Supports HDCP with DVI-D Port
- Supports Full HD 1080p Blu-ray (BD) playback with DVI-D Port

Audio

- 5.1 CH HD Audio (Realtek ALC662 Audio Codec)
- Supports Surge Protection (ASRock Full Spike Protection)
- TI® NE5532 Premium Headset Amplifier (Supports up to 600 ohm headsets) (Line-Out on rear I/O only)

LAN

- PCIE x1 Gigabit LAN 10/100/1000 Mb/s
- Realtek RTL8111GR
- Supports Wake-On-WAN (**see CAUTION 3**)
- Supports Wake-On-LAN
- Supports Lightning/ESD Protection (ASRock Full Spike Protection)
- Supports LAN Cable Detection
- Supports Energy Efficient Ethernet 802.3az
- Supports PXE

Rear Panel I/O

- 1 x PS/2 Mouse Port
- 1 x PS/2 Keyboard Port
- 1 x D-Sub Port
- 1 x DVI-D Port
- 6 x USB 2.0 Ports (Supports ESD Protection (ASRock Full Spike Protection))
- 1 x RJ-45 LAN Port with LED (ACT/LINK LED and SPEED LED)
- HD Audio Jacks: Line in / Front Speaker / Microphone

Storage

- 6 x SATA2 3.0 Gb/s Connectors, support RAID (RAID 0, RAID 1 and RAID 10), NCQ, AHCI and Hot Plug

- Connector**
- 1 x Print Port Header
 - 1 x TPM Header
 - 2 x CPU Fan Connectors (1 x 4-pin, 1 x 3-pin)
 - 2 x Chassis Fan Connectors (1 x 4-pin, 1 x 3-pin)
 - 1 x Power Fan Connector (3-pin)
 - 1 x 24 pin ATX Power Connector
 - 1 x 8 pin 12V Power Connector
 - 1 x PCIe Power Connector
 - 1 x Front Panel Audio Connector
 - 1 x USB Power Jumper (Ultra USB Power)
 - 2 x USB 2.0 Headers (Support 4 USB 2.0 ports)
(Supports ESD Protection (ASRock Full Spike Protection))

- BIOS Feature**
- 64Mb AMI UEFI Legal BIOS with GUI support
 - Supports “Plug and Play”
 - ACPI 1.1 Compliant wake up events
 - Supports jumperfree
 - SMBIOS 2.3.1 support
 - DRAM, CPU, SB Voltage multi-adjustment

- Support CD**
- Drivers, Utilities, AntiVirus Software (Trial Version), Google Chrome Browser and Toolbar, Start8 (30 days trial)

- Hardware Monitor**
- CPU temperature sensing
 - Chassis temperature sensing
 - CPU Fan Tachometer
 - Chassis Fan Tachometer
 - CPU/Chassis Quiet Fan
 - CPU/Chassis Fan multi-speed control
 - Voltage monitoring: +12V, +5V, +3.3V, Vcore

- OS**
- Microsoft® Windows® 10 32-bit / 10 64-bit / 8.1 32-bit / 8.1 64-bit / 8 32-bit / 8 64-bit / 7 32-bit / 7 64-bit
 - * For the updated Windows® 10 driver, please visit ASRock’s website for details: <http://www.asrock.com>
 - * Carrizo FM2r2 processor supports Windows® 10 64-bit / 8.1 64-bit / 7 32-bit / 7 64-bit only.

Certifications

- FCC, CE, WHQL
- ErP/EuP ready (ErP/EuP ready power supply is required)

* For detailed product information, please visit our website: <http://www.asrock.com>

WARNING

Please realize that there is a certain risk involved with overclocking, including adjusting the setting in the BIOS, applying Untied Overclocking Technology, or using third-party overclocking tools. Overclocking may affect your system's stability, or even cause damage to the components and devices of your system. It should be done at your own risk and expense. We are not responsible for possible damage caused by overclocking.

CAUTION!

1. Whether 1866/1600MHz memory speed is supported depends on the CPU you adopt. If you want to adopt DDR3 1866/1600 memory module on this motherboard, please refer to the memory support list on our website for the compatible memory modules.
ASRock website <http://www.asrock.com>
2. Due to the operating system limitation, the actual memory size may be less than 4GB for the reservation for system usage under Windows® 10 / 8.1 / 8 / 7. For Windows® 64-bit OS with 64-bit CPU, there is no such limitation. You can use ASRock XFast RAM to utilize the memory that Windows® cannot use.
3. Wake-On-WAN allows you to wake up this system from remote mobile devices, such as smart phones, tables, or other PCs. It needs third-party softwares and applications to utilize this feature. Please visit our website for Home Cloud topic.

1.3 Unique Features



ASRock A-Tuning

A-Tuning is ASRock's multi purpose software suite with a new interface, more new features and improved utilities, including XFast RAM, Dehumidifier, Good Night LED, FAN-Tastic Tuning, OC Tweaker and a whole lot more.



ASRock Instant Boot

ASRock Instant Boot allows you to turn on your PC in just a few seconds, provides a much more efficient way to save energy, time, money, and improves system running speed for your system. It leverages the S3 and S4 ACPI features which normally enable the Sleep/Standby and Hibernation modes in Windows® to shorten boot up time. By calling S3 and S4 at specific timing during the shutdown and startup process, Instant Boot allows you to enter your Windows® desktop in a few seconds.



ASRock Instant Flash

ASRock Instant Flash is a BIOS flash utility embedded in Flash ROM. This convenient BIOS update tool allows you to update system BIOS without entering operating systems first like MS-DOS or Windows®. With this utility, you can press the <F6> key during the POST or the <F2> key to enter into the BIOS setup menu to access ASRock Instant Flash. Just launch this tool and save the new BIOS file to your USB flash drive, floppy disk or hard drive, then you can update your BIOS only in a few clicks without preparing an additional floppy diskette or other complicated flash utility. Please be noted that the USB flash drive or hard drive must use FAT32/16/12 file system.



ASRock APP Charger

If you desire a faster, less restricted way of charging your Apple devices, such as iPhone/iPad/iPod Touch, ASRock has prepared a wonderful solution for you - ASRock APP Charger. Simply install the APP Charger driver, it makes your iPhone charge much quickly from your computer and up to 40% faster than before. ASRock APP Charger allows you to quickly charge many Apple devices simultaneously and even supports continuous charging when your PC enters into Standby mode (S1),

Suspend to RAM (S3), hibernation mode (S4) or power off (S5). With APP Charger driver installed, you can easily enjoy the marvelous charging experience.



ASRock XFast LAN

ASRock XFast LAN provides a faster internet access, which includes the benefits listed below. LAN Application Prioritization: You can configure your application's priority ideally and/or add new programs. Lower Latency in Game: After setting online game's priority higher, it can lower the latency in games. Traffic Shaping: You can watch Youtube HD videos and download simultaneously. Real-Time Analysis of Your Data: With the status window, you can easily recognize which data streams you are transferring currently.



ASRock XFast RAM

ASRock XFast RAM is included in A-Tuning. It fully utilizes the memory space that cannot be used under Windows® 32-bit operating systems. ASRock XFast RAM shortens the loading time of previously visited websites, making web surfing faster than ever. And it also boosts the speed of Adobe Photoshop 5 times faster. Another advantage of ASRock XFast RAM is that it reduces the frequency of accessing your SSDs or HDDs in order to extend their lifespan.



ASRock Crashless BIOS

ASRock Crashless BIOS allows users to update their BIOS without fear of failing. If power loss occurs during the BIOS update process, ASRock Crashless BIOS will automatically finish the BIOS update procedure after regaining power. Please note that BIOS files need to be placed in the root directory of your USB disk. Only USB2.0 ports support this feature.



ASRock OMG (Online Management Guard)

Administrators are able to establish an internet curfew or restrict internet access at specified times via OMG. You may schedule the starting and ending hours of internet access granted to other users. In order to prevent users from bypassing OMG, guest accounts without permission to modify the system time are required.



ASRock Internet Flash

ASRock Internet Flash searches for available UEFI firmware updates from our servers. In other words, the system can auto-detect the latest UEFI from our servers and flash them without entering Windows® OS.



ASRock UEFI System Browser

ASRock UEFI system browser is a useful tool included in graphical UEFI. It can detect the devices and configurations that users are currently using in their PC. With the UEFI system browser, you can easily examine the current system configuration in UEFI setup.



ASRock UEFI Tech Service

Contact ASRock Tech Service by sending a support request from the UEFI setup utility if you are having trouble with your PC.



ASRock Dehumidifier Function

Users may prevent motherboard damages due to dampness by enabling “Dehumidifier Function”. When enabling Dehumidifier Function, the computer will power on automatically to dehumidify the system after entering S4/S5 state.



ASRock Easy RAID Installer

ASRock Easy RAID Installer can help you to copy the RAID driver from a support CD to your USB storage device. After copying the RAID driver to your USB storage device, please change “SATA Mode” to “RAID”, then you can start installing the OS in RAID mode.



ASRock Easy Driver Installer

For users that don't have an optical disk drive to install the drivers from our support CD, Easy Driver Installer is a handy tool in the UEFI that installs the LAN driver to your system via an USB storage device, then downloads and installs the other required drivers automatically.



ASRock Interactive UEFI

ASRock Interactive UEFI is a blend of system configuration tools, cool sound effects and stunning visuals. The unprecedented UEFI provides a more attractive interface and brings a lot more amusing.



ASRock Fast Boot

With ASRock's exclusive Fast Boot technology, it takes less than 1.5 seconds to logon to Windows® 8 from a cold boot. No more waiting! The speedy boot will completely change your user experience and behavior.



ASRock X-Boost

Brilliantly designed for combo overclocking, ASRock X-Boost Technology is able to unleash the hidden power of your CPUs. Simply press "X" when turning on the PC, X-Boost will automatically overclock the relative components to get up to 15.77% performance boost! With the smart X-Boost, overclocking CPU can become a near one-button process.



ASRock Restart to UEFI

Windows® 8 brings the ultimate boot up experience. The lightning boot up speed makes it hard to access the UEFI setup. ASRock Restart to UEFI technology is designed for those requiring frequent UEFI access. It is included in ASRock's exclusive all-in-one A-Tuning tuning program that allows users to easily enter the UEFI automatically when turning on the PC next time. Just simply enable this function; the PC will be assured to access the UEFI directly in the very beginning.



ASRock Good Night LED

ASRock Good Night LED technology offers you a better sleeping environment by extinguishing the unessential LEDs. By enabling Good Night LED in the BIOS, the LAN/Power/HDD LEDs will be switched off when the system is powered on. Good Night LED will automatically switch off the Power and Keyboard LEDs when the system enters into Standby/Hibernation mode as well.



ASRock USB Key

In a world where time is money, why waste precious time everyday typing usernames to log in to Windows? Why should we even bother memorizing those foot long passwords? Just plug in the USB Key and let your computer log in to windows automatically!



ASRock FAN-Tastic Tuning

ASRock FAN-Tastic Tuning is included in A-Tuning. Configure up to five different fan speeds using the graph. The fans will automatically shift to the next speed level when the assigned temperature is met.

2. Installation

This is an ATX form factor motherboard. Before you install the motherboard, study the configuration of your chassis to ensure that the motherboard fits into it.

Pre-installation Precautions

Take note of the following precautions before you install motherboard components or change any motherboard settings.



Before you install or remove any component, ensure that the power is switched off or the power cord is detached from the power supply. Failure to do so may cause severe damage to the motherboard, peripherals, and/or components.

1. Unplug the power cord from the wall socket before touching any component.
2. To avoid damaging the motherboard components due to static electricity, NEVER place your motherboard directly on the carpet or the like. Also remember to use a grounded wrist strap or touch a safety grounded object before you handle components.
3. Hold components by the edges and do not touch the ICs.
4. Whenever you uninstall any component, place it on a grounded anti-static pad or in the bag that comes with the component.
5. When placing screws into the screw holes to secure the motherboard to the chassis, please do not over-tighten the screws! Doing so may damage the motherboard.

2.1 CPU Installation

Step 1. Unlock the socket by lifting the lever up to a 90° angle.

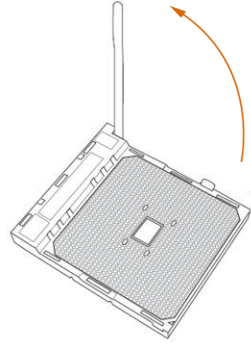

Step 2. Position the CPU directly above the socket such that the CPU corner with the golden triangle matches the socket corner with a small triangle.

Step 3. Carefully insert the CPU into the socket until it fits in place.



The CPU fits only in one correct orientation. DO NOT force the CPU into the socket to avoid bending of the pins.

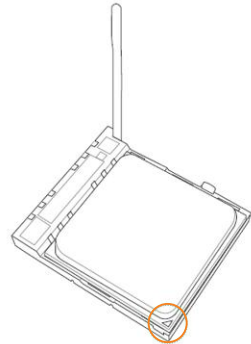

Step 4. When the CPU is in place, press it firmly on the socket while you push down the socket lever to secure the CPU. The lever clicks on the side tab to indicate that it is locked.

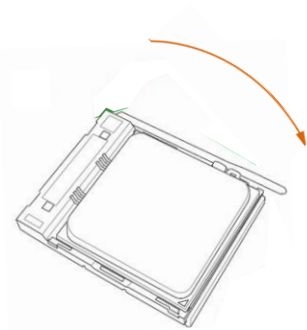

2.2 Installation of CPU Fan and Heatsink

After you install the CPU into this motherboard, it is necessary to install a larger heatsink and cooling fan to dissipate heat. You also need to spray thermal grease between the CPU and the heatsink to improve heat dissipation. Make sure that the CPU and the heatsink are securely fastened and in good contact with each other. Then connect the CPU fan to the CPU FAN connector (CPU_FAN1 and CPU_FAN2, see Page 1, No. 3 and No. 4). For proper installation, please kindly refer to the instruction manuals of the CPU fan and the heatsink.

2.3 Installation of Memory Modules (DIMM)

This motherboard provides two 240-pin DDR3 (Double Data Rate 3) DIMM slots, and supports Dual Channel Memory Technology.



1. For dual channel configuration, you always need to install identical (the same brand, speed, size and chip-type) DDR3 DIMM pairs.
2. It is unable to activate Dual Channel Memory Technology with only one memory module installed.
3. It is not allowed to install a DDR or DDR2 memory module into a DDR3 slot; otherwise, this motherboard and DIMM may be damaged.



The DIMM only fits in one correct orientation. It will cause permanent damage to the motherboard and the DIMM if you force the DIMM into the slot at incorrect orientation.

1

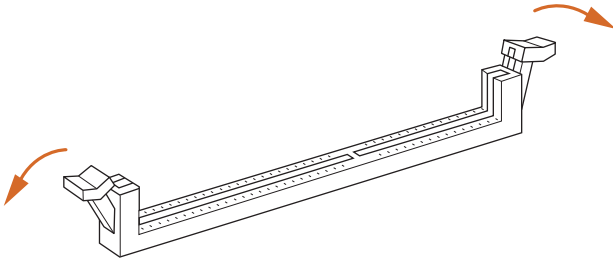

2

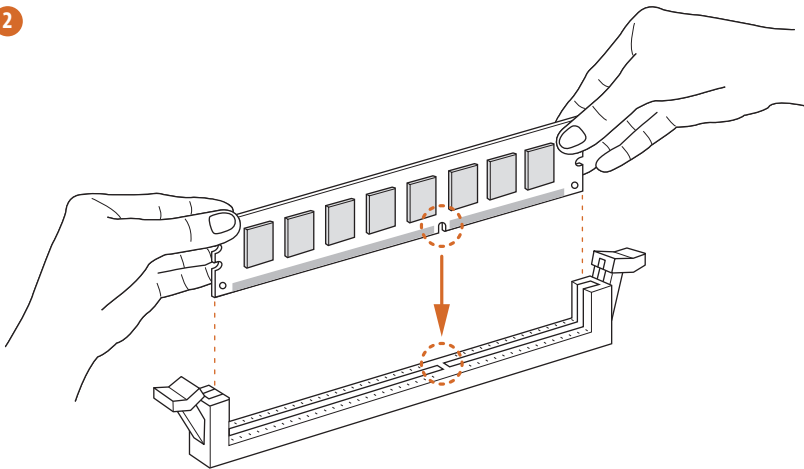

3

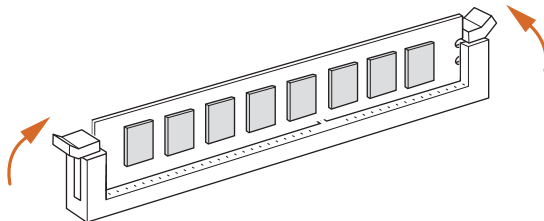

2.4 Expansion Slots (PCI and PCI Express Slots)

There are 4 PCI Express slots on this motherboard.



Before installing an expansion card, please make sure that the power supply is switched off or the power cord is unplugged. Please read the documentation of the expansion card and make necessary hardware settings for the card before you start the installation.

PCIE Slots:

PCIE1 (PCIe 3.0 x16 slot) is used for PCI Express x16 lane width graphics cards

PCIE2 / PCIE3 / PCIE4 (PCIe 2.0 x1 slot) is used for PCI Express cards with x1 lane width cards

2.5 Jumpers Setup

The illustration shows how jumpers are setup. When the jumper cap is placed on pins, the jumper is “Short”. If no jumper cap is placed on pins, the jumper is “Open”. The illustration shows a 3-pin jumper whose pin1 and pin2 are “Short” when jumper cap is placed on these 2 pins.

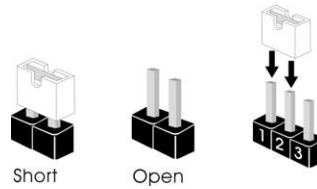

Jumper	Setting	Description
Clear CMOS Jumper (CLRCMOS1) (see p.1, No. 8)	<div style="display: flex; justify-content: space-around;"> <div style="text-align: center;"> <p>1_2</p> <p>Default</p> </div> <div style="text-align: center;"> <p>2_3</p> <p>Clear CMOS</p> </div> </div>	

Note: CLRCMOS1 allows you to clear the data in CMOS. To clear and reset the system parameters to default setup, please turn off the computer and unplug the power cord from the power supply. After waiting for 15 seconds, use a jumper cap to short pin2 and pin3 on CLRCMOS1 for 5 seconds. However, please do not clear the CMOS right after you update the BIOS. If you need to clear the CMOS when you just finish updating the BIOS, you must boot up the system first, and then shut it down before you do the clear-CMOS action. Please be noted that the password, date, time, user default profile, 1394 GUID and MAC address will be cleared only if the CMOS battery is removed.

USB Power Jumper (3-pin USB01_PWR1) (see p.1, No. 24)	<div style="text-align: center;"> <p>1_2</p> <p>+5V (Default)</p> </div>	<div style="text-align: center;"> <p>2_3</p> <p>+5VSB</p> </div>
---	--	--

Note: USB Power Jumper is specifically designed for users who use LED keyboard / mouse. (only for the USB01 ports)

Pin 1-2 shorted (default):

Stable voltage and high current is provided for LED keyboard / mouse. The backlight of your keyboard / mouse will be OFF when the PC is off.

Pin 2-3 shorted:

+5VSB voltage is provided for LED keyboard / mouse. Enable the wake-up function of your keyboard / mouse.

The backlight of your keyboard / mouse will be ON when the PC is in standby mode.

2.6 Onboard Headers and Connectors



Onboard headers and connectors are NOT jumpers. Do NOT place jumper caps over these headers and connectors. Placing jumper caps over the headers and connectors will cause permanent damage of the motherboard!

Serial ATA2 Connectors

(SATA_1: see p.1, No. 15)
 (SATA_2: see p.1, No. 16)
 (SATA_3: see p.1, No. 14)
 (SATA_4: see p.1, No. 13)
 (SATA_5: see p.1, No. 12)
 (SATA_6: see p.1, No. 11)

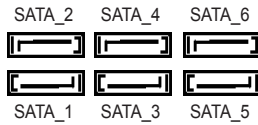

These six Serial ATA2 (SATA2) connectors support SATA data cables for internal storage devices. The current SATA2 interface allows up to 3.0 Gb/s data transfer rate.

USB 2.0 Headers

(9-pin USB45)
 (see p.1 No. 17)
 (9-pin USB67)
 (see p.1 No. 18)

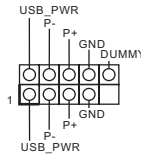

Besides six default USB 2.0 ports on the I/O panel, there are two USB 2.0 headers on this motherboard. Each USB 2.0 header can support two USB 2.0 ports.

Front Panel Audio Header

(9-pin HD_AUDIO1)
 (see p.1 No. 21)

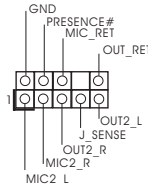

This is an interface for the front panel audio cable that allows convenient connection and control of audio devices.



1. High Definition Audio supports Jack Sensing, but the panel wire on the chassis must support HDA to function correctly. Please follow the instruction in our manual and chassis manual to install your system.
2. If you use AC'97 audio panel, please install it to the front panel audio header as below:
 - A. Connect Mic_IN (MIC) to MIC2_L.
 - B. Connect Audio_R (RIN) to OUT2_R and Audio_L (LIN) to OUT2_L.
 - C. Connect Ground (GND) to Ground (GND).
 - D. MIC_RET and OUT_RET are for HD audio panel only. You don't need to connect them for AC'97 audio panel.

E. To activate the front mic.

For Windows® 8.1 / 8.1 64-bit / 8 / 8 64-bit / 7 / 7 64-bit / XP / XP 64-bit OS: Go to the "FrontMic" Tab in the Realtek Control panel. Adjust "Recording Volume".

System Panel Header

(9-pin PANEL1)

(see p.1 No. 10)

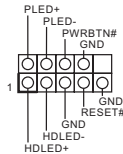

This header accommodates several system front panel functions.



Connect the power switch, reset switch and system status indicator on the chassis to this header according to the pin assignments below. Note the positive and negative pins before connecting the cables.

PWRBTN (Power Switch):

Connect to the power switch on the chassis front panel. You may configure the way to turn off your system using the power switch.

RESET (Reset Switch):

Connect to the reset switch on the chassis front panel. Press the reset switch to restart the computer if the computer freezes and fails to perform a normal restart.

PLED (System Power LED):

Connect to the power status indicator on the chassis front panel. The LED is on when the system is operating. The LED keeps blinking when the system is in S1 sleep state. The LED is off when the system is in S3/S4 sleep state or powered off (S5).

HDLED (Hard Drive Activity LED):

Connect to the hard drive activity LED on the chassis front panel. The LED is on when the hard drive is reading or writing data.

The front panel design may differ by chassis. A front panel module mainly consists of power switch, reset switch, power LED, hard drive activity LED, speaker and etc. When connecting your chassis front panel module to this header, make sure the wire assignments and the pin assignments are matched correctly.

Chassis Speaker Header

(4-pin SPEAKER 1)

(see p.1 No. 9)

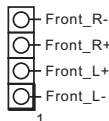

Please connect the chassis speaker to this header.

Chassis and Power Fan Connectors

(3-pin CHA_FAN1)
(see p.1 No. 7)

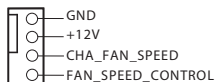

Please connect the fan cable to the fan connector and match the black wire to the ground pin.

(3-pin CHA_FAN2)
(see p.1 No. 23)

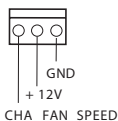

(3-pin PWR_FAN1)
(see p.1 No. 2)

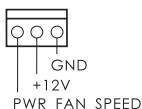

CPU Fan Connector

(4-pin CPU_FAN1)
(see p.1 No. 3)

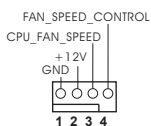

Please connect the CPU fan cable to the connector and match the black wire to the ground pin.

(3-pin CPU_FAN2)
(see p.1, No. 4)

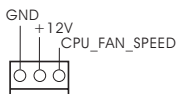

Though this motherboard provides 4-Pin CPU fan (Quiet Fan) support, the 3-Pin CPU fan still can work successfully even without the fan speed control function. If you plan to connect the 3-Pin CPU fan to the CPU fan connector on this motherboard, please connect it to Pin 1-3.

Pin 1-3 Connected ←

3-Pin Fan Installation

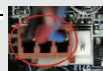

ATX Power Connector

(24-pin ATXPWR1)
(see p.1 No. 6)

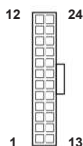

Please connect an ATX power supply to this connector.



Though this motherboard provides 24-pin ATX power connector, it can still work if you adopt a traditional 20-pin ATX power supply. To use the 20-pin ATX power supply, please plug your power supply along with Pin 1 and Pin 13.

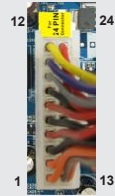

20-Pin ATX Power Supply Installation

ATX 12V Power Connector

(8-pin ATX12V1)
(see p.1 No. 1)

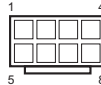

Please connect an ATX 12V power supply to this connector.



Though this motherboard provides 8-pin ATX 12V power connector, it can still work if you adopt a traditional 4-pin ATX 12V power supply. To use the 4-pin ATX power supply, please plug your power supply along with Pin 1 and Pin 5.

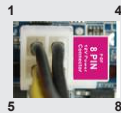

4-Pin ATX 12V Power Supply Installation

PCIe Power Connector

(4-pin PCIE_PWR1)
(see p.1, No. 22)



Please connect a 4 pin molex power cable to this connector when more than three graphics cards are installed.

Print Port Header

(25-pin LPT1)
(see p.1, No. 20)

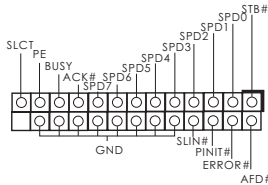

This is an interface for print port cable that allows convenient connection of printer devices.

TPM Header

(17-pin TPMS1)
(see p.1, No. 19)

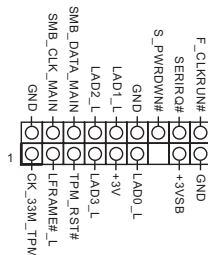

This connector supports Trusted Platform Module (TPM) system, which can securely store keys, digital certificates, passwords, and data. A TPM system also helps enhance network security, protects digital identities, and ensures platform integrity.

1. Einführung

Wir danken Ihnen für den Kauf des ASRock **FM2A58M+ BTC** Motherboard, ein zuverlässiges Produkt, welches unter den ständigen, strengen Qualitätskontrollen von ASRock gefertigt wurde. Es bietet Ihnen exzellente Leistung und robustes Design, gemäß der Verpflichtung von ASRock zu Qualität und Halbarkeit. Diese Schnellinstallationsanleitung führt in das Motherboard und die schrittweise Installation ein. Details über das Motherboard finden Sie in der Bedienungsanleitung auf der Support-CD.



Da sich Motherboard-Spezifikationen und BIOS-Software verändern können, kann der Inhalt dieses Handbuches ebenfalls jederzeit geändert werden. Für den Fall, dass sich Änderungen an diesem Handbuch ergeben, wird eine neue Version auf der ASRock-Website, ohne weitere Ankündigung, verfügbar sein. Die neuesten Grafikkarten und unterstützten CPUs sind auch auf der ASRock-Website aufgelistet.

ASRock-Website: <http://www.asrock.com>

Wenn Sie technische Unterstützung zu Ihrem Motherboard oder spezifische Informationen zu Ihrem Modell benötigen, besuchen Sie bitte unsere Webseite:

www.asrock.com/support/index.asp

1.1 Kartoninhalt

ASRock **FM2A58M+ BTC** Motherboard (ATX-Formfaktor)

ASRock **FM2A58M+ BTC** Schnellinstallationsanleitung

ASRock **FM2A58M+ BTC** Support-CD

Zwei Serial ATA (SATA) -Datenkabel (optional)

Ein I/O Shield

1.2 Spezifikationen

- Plattform**
- Micro-ATX-Formfaktor
 - Alle Feste Kondensator-design
 - PCB mit hochverdichtetem Glasfasergewebe

- CPU**
- Unterstützt Prozessoren für Sockel FM2+ (95 W) / FM2 (100 W)

- Chipsatz**
- AMD A58 FCH (Bolton-D2)
 - 4 + 2-Stromphasendesign

- Speicher**
- Unterstützung von Dual-Kanal-Speichertechnologie
 - 2 x Steckplätze für DDR3
 - Unterstützt DDR3 1866/1600/1333/1066 non-ECC, ungepufferter Speicher
 - Max. Kapazität des Systemspeichers: 32GB
 - Unterstützt Intel® Extreme Memory Profile (XMP)1.3/1.2
 - Unterstützt AMDs Memory Profile Technology (AMP)
 - 15-µ-Goldkontakt in DIMM-Steckplätzen

- Erweiterungssteckplätze**
- 1 x PCI Express 3.0 x16-Steckplätze (PCIe1: x16-Modus)
 - * PCIe 3.0 wird nur mit FM2+-Prozessor unterstützt.FM2-Prozessor unterstützt nur PCIe 2.0.
 - 3 x PCI Express 2.0 x1-Steckplätze
 - 15-µ-Goldkontakt in VGA-PCIe-Steckplatz (PCIe1)

- Onboard-VGA**
- Integrierte Grafikkarte der AMD Radeon™ R7/R5-Serie in APU der A-Serie
 - DirectX 11.1, Pixel Shader 5.0 mit FM2+-Prozessor. DirectX 11, Pixel Shader 5.0 mit FM2-Prozessor.
 - Maximal gemeinsam genutzter Speicher 2GB
 - Doppel-VGA Ausgabe: unterstützt DVI-D und D-Sub Ports durch unabhängige Bildschirmanzeige Kontrolleure
 - Unterstützt Dual-link DVI-D mit einer maximalen Auflösung von 2560 x 1600 bei 60 Hz

- Unterstützt D-Sub mit einer maximalen Auflösung von 1920 x 1200 bei 60 Hz
- Unterstützt AMD Steady Video™ 2.0: Neuartige Funktion der Videonachbearbeitung für automatische Reduzierung von Bildschwankungen bei Heim-/Online-Videos
- Unterstützt HDCP-Funktion mit DVI-D-Port
- Unterstützt 1080p Blu-ray (BD) / HD-DVD-Wiedergabe mit DVI-D-Port

Audio

- 5.1 CH HD Audio (Realtek ALC662 Audio Codec)
- Unterstützt Überspannungsschutz (ASRocks Komplettschutz vor Spannungsspitzen)
- TI® NE5532 (unterstützt erstklassigen Headset-Verstärker mit bis zu 600 Ohm) (Line-Ausgang nur an hinterem I/O)

LAN

- PCIE x1 Gigabit LAN 10/100/1000 Mb/s
- Realtek RTL8111GR
- Unterstützt Wake-On-WAN
- Unterstützt Wake-On-LAN
- Unterstützt Schutz vor Blitzschlag/elektrostatischer Entladung (ASRocks Komplettschutz vor Spannungsspitzen)
- Unterstützt LAN-Kabelerkennung
- Unterstützt energieeffizientes Ethernet 802.3az
- Unterstützt PXE

E/A-Anschlüsse an der Rückseite

- 1 x PS/2-Mausanschluss
- 1 x PS/2-Tastaturanschluss
- 1 x D-Sub port
- 1 x DVI-D port
- 6 x Standard-USB 2.0-Anschlüsse (Unterstützt Schutz vor elektrostatischer Entladung (ASRocks Komplettschutz vor Spannungsspitzen))
- 1 x RJ-45 LAN Port mit LED (ACT/LINK LED und SPEED LED)
- HD Audiobuchse: Audioeingang / Lautsprecher vorne / Mikrofon

- Speicher**
- 6 x SATA 2-Anschluss mit 3,0 Gb/s, unterstützt RAID- (RAID 0, RAID 1 und RAID 10), NCQ-, AHCI- und „Hot Plugging“-Funktionen

**An-
schlüsse**

- 1 x Druckerport-Anschlussleiste
- 1 x TPM-Stiftleiste
- 2 x CPU Lüfter-Anschluss (1 x 4-pin, 1 x 3-pin)
- 2 x Gehäuselüfter-Anschluss (1 x 4-pin, 1 x 3-pin)
- 1 x Stromlüfter-Anschluss (3-pin)
- 1 x 24-pin ATX-Netz-Header
- 1 x 8-pin Anschluss für 12V-ATX-Netzteil
- 1 x 1 PCIe-Stromanschluss
- 1 x Anschluss für Audio auf der Gehäusevorderseite
- 1 x USB-Stromversorgungsbrücke (Ultra-USB-Stromversorgung)
- 2 x USB 2.0-Anschlüsse (Unterstützung 4 zusätzlicher USB 2.0-Anschlüsse) (Unterstützt Schutz vor elektrostatischer Entladung (ASROcks Komplettschutz vor Spannungsspitzen))

BIOS

- 64Mb AMIs Legal BIOS UEFI mit GUI-Unterstützung
- Unterstützung für "Plug and Play"
- ACPI 1.1-Weckfunktionen
- JumperFree-Modus
- SMBIOS 2.3.1
- DRAM, CPU, SB Stromspannung Multianpassung

**Support-
CD**

- Pilotes, utilitaires, logiciel anti-virus (Version d'essai), Google ChromeBrowser et Toolbar, Start8 (30 jours d'évaluation)

**Hardware
Monitor**

- CPU-Temperatursensor
- Motherboardtemperaturerkennung
- Drehzahlmessung für CPU Lüfter
- Drehzahlmessung für Gehäuselüfter
- Geräuscharmer CPU-/Gehäuselüfter
- Mehrstufige Geschwindigkeitsteuerung für CPU-/
- Gehäuselüfter Spannungüberwachung: +12V, +5V, +3.3V, Vcore

**Betriebs-
systeme**

- Microsoft® Windows® 8.1 32-bit / 8.1 64-bit / 8 32-bit / 8 64-bit / 7 32-bit / 7 64-bit / XP 32-bit / XP 64-bit

**Zertifi-
zierungen**

- FCC, CE, WHQL
- Prêt pour ErP/EuP (alimentation Prêt pour ErP/EuP requise)

* Für die ausführliche Produktinformation, besuchen Sie bitte unsere Website:

<http://www.asrock.com>

1.3 Einstellung der Jumper

Die Abbildung verdeutlicht, wie Jumper gesetzt werden. Werden Pins durch Jumperkappen verdeckt, ist der Jumper "Gebrückt". Werden keine Pins durch Jumperkappen verdeckt, ist der Jumper "Offen". Die Abbildung zeigt einen 3-Pin Jumper dessen Pin1 und Pin2 "Gebrückt" sind, bzw. es befindet sich eine Jumper-Kappe auf diesen beiden Pins.

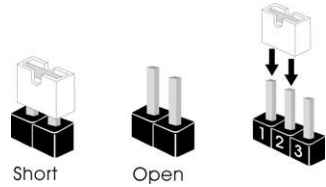

Jumper	Einstellung	Beschreibung
CMOS löschen (CLRCMOS1, 3-Pin jumper) (siehe S.1, No. 8)	<p>1_2</p> <p>Default-Einstellung</p>	<p>2_3</p> <p>CMOS löschen</p>

Hinweis: CLRCMOS1 ermöglicht Ihnen die Löschung der Daten im CMOS. Zum Löschen und Zurücksetzen der Systemparameter auf die Standardeinrichtung schalten Sie den Computer bitte aus und trennen das Netzkabel von der Stromversorgung. Warten Sie 15 Sekunden, schließen Sie dann Pin2 und Pin3 am CLRCMOS1 über einen Jumper fünf Sekunden lang kurz. Sie sollten das CMOS allerdings nicht direkt nach der BIOS-Aktualisierung löschen. Wenn Sie das CMOS nach Abschluss der BIOS-Aktualisierung löschen müssen, fahren Sie zuerst das System hoch. Fahren Sie es dann vor der CMOS-Löschung herunter. Bitte beachten Sie, dass Kennwort, Datum, Uhrzeit, benutzerdefiniertes Profil, 1394 GUID und MAC-Adresse nur gelöscht werden, wenn die CMOS-Batterie entfernt wird.

USB-Stromversorgungsbrücke (USB01_PWR1, dreipolig) (siehe S.1, No. 24)	<p>1_2</p> <p>+5V (Standard)</p>	<p>2_3</p> <p>+5VSB</p>
--	---	--------------------------------

Hinweis:

Die USB-Stromversorgungsbrücke wurde speziell für Anwender entwickelt, die Tastaturen oder Mäuse mit LED-Beleuchtung nutzen. (nur für USB01-Anschluss)

Pins 1 und 2 gebrückt (Standard):

Stabile Spannung und hoher Strom werden für LED-Tastatur / -Maus bereitgestellt. Tastatur und Maus werden bei abgeschaltetem PC nicht beleuchtet.

Pins 2 und 3 gebrückt:

+5-VSB-Spannung wird für LED-Tastatur / -Maus bereitgestellt. Aufwecken des Systems durch Tastatur-/Mausaktivität möglich. Tastatur und Maus werden bei abgeschaltetem PC beleuchtet.

1.4 Anschlüsse



Anschlussleisten sind KEINE Jumper. Setzen Sie KEINE Jumperkappen auf die Pins der Anschlussleisten. Wenn Sie die Jumperkappen auf die Anschlüsse setzen, wird das Motherboard permanent beschädigt!

Anschluss

Beschreibung

Seriell-ATA2-Anschlüsse

(SATA_1: siehe S.1 - No. 15)

(SATA_2: siehe S.1 - No. 16)

(SATA_3: siehe S.1 - No. 14)

(SATA_4: siehe S.1 - No. 13)

(SATA_5: siehe S.1 - No. 12)

(SATA_6: siehe S.1 - No. 11)

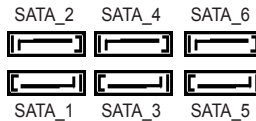

Diese sechs Serial ATA2- (SATA2-)Verbinder unterstützen SATA-Datenkabel für interne Massenspeichergeräte. Die aktuelle SATA2- Schnittstelle ermöglicht eine Datenübertragungsrate bis 3,0 Gb/s.

USB 2.0-Header

(9-pol. USB45)

(siehe S.1 - No. 17)

(9-pol. USB67)

(siehe S.1 - No. 18)

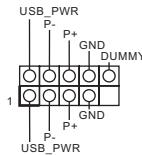

Zusätzlich zu den sechs üblichen USB 2.0-Ports an den I/O-Anschlüssen befinden sich zwei USB 2.0-Anschlussleisten am Motherboard. Pro USB 2.0-Anschlussleiste werden zwei USB 2.0-Ports unterstützt.

Anschluss für Audio auf der Gehäusevorderseite

(9-Pin HD_AUDIO1)

(siehe S.1 - No. 21)

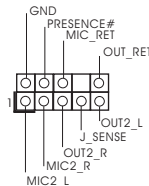

Dieses Interface zu einem Audio-Panel auf der Vorderseite Ihres Gehäuses, ermöglicht Ihnen eine bequeme Anschlussmöglichkeit und Kontrolle über Audio-Geräte.



- High Definition Audio unterstützt Jack Sensing (automatische Erkennung falsch angeschlossener Geräte), wobei jedoch die Bildschirmverdrahtung am Gehäuse HDA unterstützen muss, um richtig zu funktionieren. Beachten Sie bei der Installation im System die Anweisungen in unserem Handbuch und im Gehäusehandbuch.
- Wenn Sie die AC'97-Audioleiste verwenden, installieren Sie diese wie nachstehend beschrieben an der Front-Audioanschlussleiste:
 - Schließen Sie Mic_IN (MIC) an MIC2_L an.

- B. Schließen Sie Audio_R (RIN) an OUT2_R und Audio_L (LIN) an OUT2_L an.
 C. Schließen Sie Ground (GND) an Ground (GND) an.
 D. MIC_RET und OUT_RET sind nur für den HD-Audioanschluss gedacht. Diese Anschlüsse müssen nicht an die AC'97-Audioleiste angeschlossen werden.
 E. So aktivieren Sie das Mikrofon an der Vorderseite.
 Bei den Betriebssystemen Windows® 8.1 / 8.1 64 Bit / 8 / 8 64 Bit / 7 / 7 64 Bit / XP / XP 64 Bit: Wählen Sie im Realtek-Bedienfeld die „FrontMic“ (Vorderes Mikrofon)-Registerkarte. Passen Sie die „Recording Volume“ (Aufnahmelautstärke) an.

System Panel-Header

(9-pin PANEL1)

(siehe S.1 - No. 10)

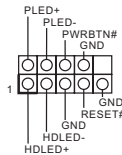

Dieser Header unterstützt mehrere Funktion der Systemvorderseite.



Schließen Sie die Ein-/Austaste, die Reset-Taste und die Systemstatusanzeige am Gehäuse an diesen Header an; befolgen Sie dabei die nachstehenden Hinweise zur Pinbelegung. Beachten Sie die positiven und negativen Pins, bevor Sie die Kabel anschließen.

PWRBTN (Ein-/Ausschalter):

Zum Anschließen des Ein-/Ausschalters an der Frontblende des Gehäuses. Sie können konfigurieren, wie das System mit Hilfe des Ein-/Ausschalters ausgeschaltet werden können soll.

RESET (Reset-Taste):

Zum Anschließen der Reset-Taste an der Frontblende des Gehäuses. Mit der Reset-Taste können Sie den Computer im Falle eines Absturzes neu starten.

PLED (Systembetriebs-LED):

Zum Anschließen der Betriebsstatusanzeige an der Frontblende des Gehäuses. Die LED leuchtet, wenn das System in Betrieb ist. Die LED blinkt, wenn sich das System im Ruhezustand S1 befindet. Die LED schaltet sich aus, wenn sich das System in den Modi S3/S4 befindet oder ausgeschaltet ist (S5).

HDLED (Festplattenaktivitäts-LED):

Zum Anschließen der Festplattenaktivitäts-LED an der Frontblende des Gehäuses. Die LED leuchtet, wenn die Festplatte Daten liest oder schreibt.

Das Design der Frontblende kann je nach Gehäuse variieren. Ein Frontblendenmodul besteht hauptsächlich aus einer Ein-/Austaste, einer Reset-Taste, einer Betriebs-LED, einer Festplattenaktivitäts-LED, Lautsprechern, etc. Stellen Sie beim Anschließen des Frontblendenmoduls Ihres Gehäuses an diesem Header sicher, dass die Kabel- und Pinbelegung korrekt übereinstimmen.

Gehäuselautsprecher-Header

(4-pin SPEAKER1)

(siehe S.1 - No. 9)

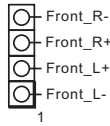

Schließen Sie den Gehäuselautsprecher an diesen Header an.

Gehäuse- und Stromlüfteranschlüsse

(4-pin CHA_FAN1)

(siehe S.1 - No. 7)

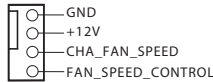

Verbinden Sie die Lüfterkabel mit den Lüfteranschlüssen, wobei der schwarze Draht an den Schutzleiterstift angeschlossen wird.

(3-pin CHA_FAN2)

(siehe S.1 - No. 23)

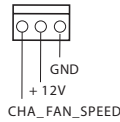

(3-pin PWR_FAN1)

(siehe S.1 - No. 2)

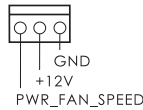

CPU-Lüfteranschluss

(4-pin CPU_FAN1)

(siehe S.1 - No. 3)

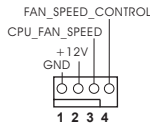

Verbinden Sie das CPU - Lüfterkabel mit diesem Anschluss und passen Sie den schwarzen Draht dem Erdungsstift an.



Obwohl dieses Motherboard einen vierpoligen CPU-Lüfteranschluss (Quiet Fan) bietet, können auch CPU-Lüfter mit dreipoligem Anschluss angeschlossen werden; auch ohne Geschwindigkeitsregulierung. Wenn Sie einen dreipoligen CPU-Lüfter an den CPU-Lüferanschluss dieses Motherboards anschließen möchten, verbinden Sie ihn bitte mit den Pins 1 – 3.

Pins 1–3 anschließen ←

Lüfter mit dreipoligem Anschluss installieren



(3-pin CPU_FAN2)

(siehe S.1 - No. 4)

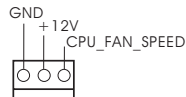

ATX-Netz-Header

(24-pin ATXPWR1)

(siehe S.1 - No. 6)

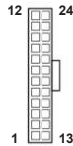

Verbinden Sie die ATX-Stromversorgung mit diesem Header.

ATX 12V Anschluss

(8-pin ATX12V1)

(siehe S.1 - No. 1)

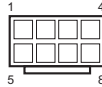

Bitte schließen Sie an diesen Anschluss die ATX 12V Stromversorgung an.



Obwohl diese Hauptplatte 8-Pin ATX 12V Stromanschluss zur Verfügung stellt, kann sie noch arbeiten, wenn Sie einen traditionellen 4-Pin ATX 12V Energieversorgung adoptieren. Um die 4-Pin ATX Energieversorgung zu verwenden, stecken Sie bitte Ihre Energieversorgung zusammen mit dem Pin 1 und Pin 5 ein.

Installation der 4-Pin ATX 12V Energieversorgung

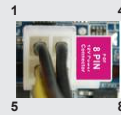

PCIe-Stromanschluss

(PCIE_PWR1, vierpolig)

(see p.1, No. 22)



Bitte schließen Sie ein vierpoliges Molex-Stromversorgungskabel an diesen Anschluss an, wenn mehr als drei Grafikkarten installiert sind.

Embase de port d'impression

(LPT1 25 broches)

(voir p.1 No. 20)

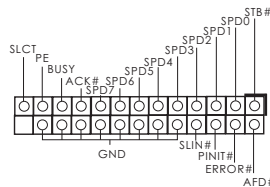

All s'agit d'une interface pour le câble du port d'impression, qui permet le raccordement pratique de périphériques d'impression.

TPM-Stiftleiste

(17-polig, TPMS1)

(siehe S. 1, Nr. 19)

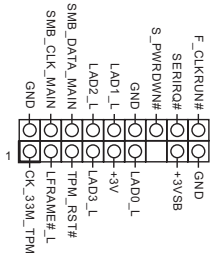

Dieser Anschluss unterstützt das Trusted Platform Module- (TPM) System, das Schlüssel, digitale Zertifikate, Kennwörter und Daten sicher aufbewahren kann. Ein TPM-System hilft zudem bei der Stärkung der Netzwerksicherheit, schützt digitale Identitäten und gewährleistet die Plattformintegrität.

1. Introduction

Merci pour votre achat d'une carte mère ASRock **FM2A58M+ BTC**, une carte mère très fiable produite selon les critères de qualité rigoureux de ASRock. Elle offre des performances excellentes et une conception robuste conformément à l'engagement d'ASRock sur la qualité et la fiabilité au long terme.

Ce Guide d'installation rapide présente la carte mère et constitue un guide d'installation pas à pas. Des informations plus détaillées concernant la carte mère pourront être trouvées dans le manuel l'utilisateur qui se trouve sur le CD d'assistance.



Les spécifications de la carte mère et le BIOS ayant pu être mis à jour, le contenu de ce manuel est sujet à des changements sans notification. Au cas où n'importe quelle modification intervenait sur ce manuel, la version mise à jour serait disponible sur le site web ASRock sans nouvel avis. Vous trouverez les listes de prise en charge des cartes VGA et CPU également sur le site Web ASRock. Site web ASRock, <http://www.asrock.com>
Si vous avez besoin de support technique en relation avec cette carte mère, veuillez consulter notre site Web pour de plus amples informations particulières au modèle que vous utilisez.
www.asrock.com/support/index.asp

1.1 Contenu du paquet

Carte mère ASRock **FM2A58M+ BTC** (Facteur de forme ATX)

Guide d'installation rapide ASRock **FM2A58M+ BTC**

CD de soutien ASRock **FM2A58M+ BTC**

Deux câbles de données de série ATA (SATA) (en option)

Un I/O Panel Shield

1.2 Spécifications

- Format**
- Facteur de forme Micro ATX
 - Accessoires de Carte mère
 - PCB High Density Glass Fabric

- CPU**
- Prend en charge les processeurs à socket FM2+ 95W / FM2 100W
 - Conception 4 + 2 Power Phase

- Chipsets**
- AMD A58 FCH (Bolton-D2)

- Mémoire**
- Compatible avec la Technologie de Mémoire à Canal Double
 - 2 x slots DIMM DDR3
 - Supporter 1866/1600/1333/1066 non-ECC, sans amortissement mémoire
 - Capacité maxi de mémoire système: 32GB
 - Prend en charge le profil de mémoire extrême Intel® (XMP)1.3/1.2
 - Prend en charge la technologie AMD Memory Profile (Profil de mémoire AMD - AMP)
 - Contact en or 15µ dans les fentes DIMM

- Slot d'extension**
- 1 x slots PCI Express 3.0 x16 (PCIE1 à mode x16)
* PCIE 3.0 est uniquement pris en charge le processeur FM2+. Avec le processeur FM2, seul PCIE 2.0 est pris en charge.
 - 3 x slots PCI Express 2.0 x1
 - Contact en or 15µ dans la fente PCIe VGA (PCIE1)

- VGA sur carte**
- APU AMD Radeon™ R7/R5 série graphiques A-series
 - DirectX 11.1, Pixel Shader 5.0 avec processeur FM2+. DirectX 11, Pixel Shader 5.0 avec processeur FM2.
 - mémoire partagée max 2GB
 - Output de VGA Duel: supporter DVI-D et D-Sub ports par les controleurs de display independents

- Prend en charge le Dual-link DVI-D avec une résolution maximale jusqu'à 2560x1600 @ 60Hz
- Prend en charge le D-Sub avec une résolution maximale jusqu'à 1920x1600 @ 60Hz
- Supporte AMD Steady Video™ 2.0: Nouvelle fonctionnalité de traitement post-vidéo pour réduction automatique des tremblements dans les clips vidéo en ligne/maison
- Prise en charge de la fonction HDCP avec ports DVI-D
- Supporter 1080p Blu-ray(BD)/ lecteur de HD-DVD avec ports DVI-D

Audio

- 5,1 CH HD Audio (Realtek ALC662 Audio Codec)
- Supporte la protection contre les surtensions (protection complète contre surges ASRock)
- TI® NE5532 (compatible Premium Headset Amplifier jusqu'à 600 Ohms) (Sortie ligne sur E/S arrière seulement)

LAN

- PCIE x1 Gigabit LAN 10/100/1000 Mb/s
- Realtek RTL8111GR
- Supporte du Wake-On-WAN
- Supporte du Wake-On-LAN
- Supporte la protection contre la foudre/ESD (protection complète contre surges ASRock)
- Prise en charge de la détection de câble LAN
- Prend en charge la norme Energy Efficient Ethernet (Ethernet à efficacité énergétique) 802.3az
- Supporte PXE

Panneau arrière

- 1 x port souris PS/2
- 1 x port clavier PS/2
- 1 x port D-Sub
- 1 x port DVI-D
- 6 x ports USB 2.0 par défaut (Supporte la protection ESD (protection complète contre surges ASRock))

Stockage

- 6 x connecteurs 3,0 Gb/s SATA2, prise en charge des fonctions RAID (RAID 0, RAID 1 et RAID 10), NCQ, AHCI et « Connexion à chaud »

Connecteurs

- 1 x embase de port d'impression
- 1 x embase TPM
- 2 x Connecteur pour ventilateur de CPU (1 x br. 4, 1 x br. 3)
- 2 x Connecteur pour ventilateur de Châssis (1 x br. 4, 1 x br. 3)
- 1 x Connecteur pour ventilateur de pouvoir (br. 3)
- 1 x br. 24 connecteur d'alimentation ATX
- 1 x br. 8 connecteur d'alimentation 12V ATX
- 1 connecteur d'alimentation PCIe
- 1 x Connecteur audio panneau avant
- 1 contact d'alimentation USB (Alimentation USB ultra)
- 2 x En-tête USB 2.0 (prendre en charge 4 ports USB 2.0 supplémentaires) (Supporte la protection ESD (protection complète contre surges ASRock))

BIOS

- 64Mb AMI UEFI Legal BIOS avec support GUI
- Support du "Plug and Play"
- Compatible pour événements de réveil ACPI 1.1
- Gestion jumperless
- Support SMBIOS 2.3.1
- DRAM, CPU, SB Tension Multi-ajustement

CD d'assistance

- Pilotes, utilitaires, logiciel anti-virus (Version d'essai), Google ChromeBrowser et Toolbar, Start8 (30 jours d'évaluation)

Surveillance système

- Détection de la température de l'UC
- Mesure de température de la carte mère
- Tachéomètre ventilateur CPU Ventilateur
- Tachéomètre ventilateur Châssis Ventilateur
- Ventilateur silencieux pour unité CPU/boîtier
- Commande de ventilateur CPU/boîtier à plusieurs vitesses

- Monitoring de la tension: +12V, +5V, +3.3V, Vcore

OS

- Microsoft® Windows® 8.1 32-bit / 8.1 64-bit / 8 32-bit / 8 64-bit / 7 32-bit / 7 64-bit / XP 32-bit / XP 64-bit

Certifications

- FCC, CE, WHQL
- Prêt pour ErP/EuP (alimentation Prêt pour ErP/EuP requise)

* Pour de plus amples informations sur les produits, s'il vous plaît visitez notre site web: <http://www.asrock.com>

1.3 Réglage des cavaliers

L'illustration explique le réglage des cavaliers. Quand un capuchon est placé sur les broches, le cavalier est « FERME ». Si aucun capuchon ne relie les broches, le cavalier est « OUVERT ». L'illustration montre un cavalier à 3 broches dont les broches 1 et 2 sont « FERMEES » quand le capuchon est placé sur ces 2 broches.

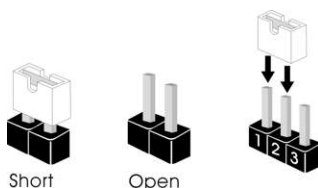

Le cavalier

Description

Effacer la CMOS

(CLRCMOS1)

(voir p.1 fig. 8)

1_2



Paramètres
par défaut

2_3



Effacer la
CMOS

Remarque : CLRCMOS1 vous permet d'effacer les données du CMOS. Pour effacer et réinitialiser les paramètres du système à la configuration originale, veuillez éteindre l'ordinateur et débrancher le cordon d'alimentation de la prise de courant. Après 15 secondes, utilisez un couvercle de jumper pour court-circuiter les broches pin2 et pin3 de CLRCMOS1 pendant 5 secondes. Veuillez cependant ne pas effacer le CMOS immédiatement après avoir mis à jour le BIOS. Si vous avez besoin d'effacer le CMOS après avoir mis à jour le BIOS, vous devez allumer en premier le système, puis l'éteindre avant de continuer avec l'opération d'effacement du CMOS. Veuillez noter que le mot de passe, la date, l'heure, le profil par défaut de l'utilisateur, 1394 GUID et l'adresse MAC seront effacés seulement si la batterie du CMOS est enlevée.

Contact d'alimentation

USB

(USB01_PWR1 3 broches)

(voir p.1 fig. 24)

1_2



5,25 V (par défaut)

2_3



+ 5 VSB

Remarque :

Le contact d'alimentation USB est spécifiquement conçu pour les utilisateurs se servant d'un clavier/souris à DEL. (seulement pour port USB01)

Broche 1-2 désactivée (par défaut) :

Une tension stable et un haut courant sont fournis pour une souris/un clavier LED

Le rétroéclairage de votre clavier/souris serait éteint lorsque le PC est éteint.

Broche 2-3 désactivée :

Une tension de +5VSB est fournie pour une souris/un clavier LED

Activez la fonction de réveil de votre clavier/souris.

Le rétroéclairage de votre clavier/souris sera activé lorsque le PC est en veille.

1.4 En-têtes et Connecteurs sur Carte



Les en-têtes et connecteurs sur carte NE SONT PAS des cavaliers. NE PAS placer les capuchons de cavalier sur ces en-têtes et connecteurs. Le fait de placer les capuchons de cavalier sur les en-têtes et connecteurs causera à la carte mère des dommages irréversibles!

Connecteurs Série ATA2

(SATA_1: voir p.1 No. 15)

(SATA_2: voir p.1 No. 16)

(SATA_3: voir p.1 No. 14)

(SATA_4: voir p.1 No. 13)

(SATA_5: voir p.1 No. 12)

(SATA_6: voir p.1 No. 11)

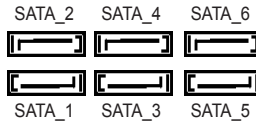

Ces six connecteurs Série

ATA2 (SATA2) prennent en charge les câbles SATA pour les périphériques de stockage internes. L'interface SATA2 actuelle permet des taux transferts de données pouvant aller jusqu'à 3,0 Gb/s.

En-tête USB 2.0

(USB45 br.9)

(voir p.1 No. 17)

(USB67 br.9)

(voir p.1 No. 18)

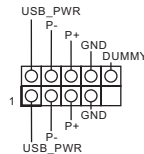

A côté des six ports USB

2.0 par défaut sur le panneau E/S, il y a deux embases USB 2.0 sur cette carte mère.

Chaque embase USB 2.0 peut prendre en charge 2 ports USB 2.0.

Connecteur audio panneau

(HD_AUDIO1 br. 9)

(voir p.1 No. 21)

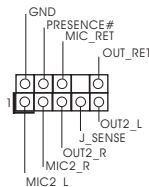

C'est une interface pour un câble avant audio en façade qui permet le branchement et le contrôle commodes de périphériques audio.



1. L'audio à haute définition (HDA) prend en charge la détection de fiche, mais le fil de panneau sur le châssis doit prendre en charge le HDA pour fonctionner correctement. Veuillez suivre les instructions dans notre manuel et le manuel de châssis afin d'installer votre système.
2. Si vous utilisez le panneau audio AC'97, installez-le sur l'adaptateur audio du panneau avant conformément à la procédure ci-dessous :
 - A. Connectez Mic_IN (MIC) à MIC2_L.
 - B. Connectez Audio_R (RIN) à OUT2_R et Audio_L (LIN) à OUT2_L.
 - C. Connectez Ground (GND) à Ground (GND).
 - D. MIC_RET et OUT_RET sont réservés au panneau audio HD. Vous n'avez pas besoin de les connecter pour le panneau audio AC'97.

Pour les systèmes d'exploitation Windows® 8.1 / 8.1 64 bits / 8 / 8 64 bits / 7 / 7 64 bits / XP / XP 64 bits : Allez sur l'onglet "FrontMic" (Micro avant) sur le Panneau de contrôle Realtek. Ajustez "Recording Volume" (Volume d'enregistrement).

En-tête du panneau système

(PANEL1 br.9)

(voir p.1 No. 10)

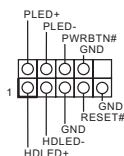

Cet en-tête permet d'utiliser plusieurs fonctions du panneau système frontal.



Connectez l'interrupteur d'alimentation, l'interrupteur de réinitialisation et l'indicateur d'état du système du châssis sur cette barrette en respectant l'affectation des broches décrite ci-dessous. Faites attention aux broches positives et négatives avant de connecter les câbles.

PWRBTN (Interrupteur d'alimentation):

Connectez ici le connecteur d'alimentation sur le panneau avant du châssis. Vous pouvez configurer la façon de mettre votre système hors tension avec l'interrupteur d'alimentation.

RESET (Interrupteur de réinitialisation):

Connectez ici le connecteur de réinitialisation sur le panneau avant du châssis. Appuyez sur l'interrupteur de réinitialisation pour redémarrer l'ordinateur s'il se bloque ou s'il n'arrive pas à redémarrer normalement.

PLED (DEL alimentation système):

Connectez ici l'indicateur d'état de l'alimentation sur le panneau avant du châssis. Ce voyant DEL est allumé lorsque le système est en marche. Le voyant DEL clignote lorsque le système est en mode veille S1. Le voyant DEL est éteint lorsque le système est en mode veille S3/ S4 ou lorsqu'il est éteint (S5).

HDLED (DEL activité du disque dur):

Connectez ici le voyant DEL d'activité du disque dur sur le panneau avant du châssis. Ce voyant DEL est allumé lorsque le disque dur est en train de lire ou d'écrire des données.

Le design du panneau avant peut varier en fonction du châssis. Un module de panneau avant consiste principalement en : interrupteur d'alimentation, interrupteur de réinitialisation, voyant DEL d'alimentation, voyant DEL d'activité du disque dur, haut-parleur, etc. Lorsque vous connectez le panneau avant de votre châssis sur cette barrette, vérifiez bien à faire correspondre les fils et les broches.

En-tête du haut-parleur
de châssis
(SPEAKER1 br. 4)
(voir p.1 No. 9)

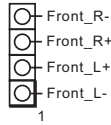

Veillez connecter le haut-parleur de châssis sur cet en-tête.

Connecteur pour châssis
et ventilateur
(CHA_FAN1 br. 4)
(voir p.1 No. 7)

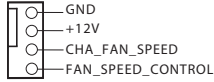

Branchez les câbles du ventilateur aux connecteurs pour ventilateur et faites correspondre le fil noir à la broche de terre.

(CHA_FAN2 br. 3)
(voir p.1 No. 23)

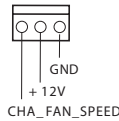

(PWR_FAN1 br. 3)
(voir p.1 No. 2)

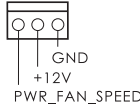

Connecteur du ventilateur
de l'UC
(CPU_FAN1 br. 4)
(voir p.1 No. 3)

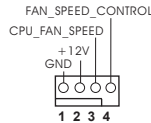

Veillez connecter le câble de ventilateur d'UC sur ce connecteur et brancher le fil noir sur la broche de terre.



Bien que cette carte mère offre un support de (Ventilateur silencieux ventilateur de CPU à 4 broches , le ventilateur de CPU à 3 broches peut bien fonctionner même sans la fonction de commande de vitesse du ventilateur. Si vous prévoyez de connecter le ventilateur de CPU à 3 broches au connecteur du ventilateur de CPU sur cette carte mère, veuillez le connecter aux broches 1-3.

Installation de ventilateur à 3 broches ←



Broches 1-3 connectées

(CPU_FAN2 br. 3)
(voir p.1 No. 4)

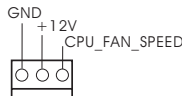

En-tête d'alimentation ATX

(ATXPWR1 br. 24)

(voir p.1 No. 6)

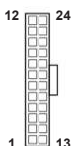

Veillez connecter l'unité d'alimentation ATX sur cet en-tête.



Bien que cette carte mère fournisse un connecteur de courant ATX 24 broches, elle peut encore fonctionner si vous adoptez une alimentation traditionnelle ATX 20 broches. Pour utiliser une alimentation ATX 20 broches, branchez à l'alimentation électrique ainsi qu'aux broches 1 et 13.

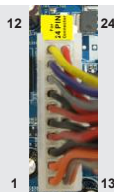

20-Installation de l'alimentation électrique ATX

Connecteur ATX 12V

(ATX12V1 br.8)

(voir p.1 No. 1)

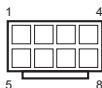

Veillez connecter une unité d'alimentation électrique ATX 12V sur ce connecteur.



Bien que cette carte mère possède 8 broches connecteur d'alimentation ATX 12V, il peut toujours travailler si vous adoptez une approche traditionnelle à 4 broches ATX 12V alimentation. Pour utiliser l'alimentation des 4 broches ATX, branchez votre alimentation avec la broche 1 et la broche 5.



4-Installation d'alimentation à 4 broches ATX 12V

Connecteur d'alimentation PCIe

(PCI_E_PWR1 4 broches)

(see p.1, No. 22)



Veillez connecter un câble d'alimentation 4 broches à ce connecteur lorsque vous installez plus de trois cartes graphiques.

Embase de port d'impression

(LPT1 25 broches)

(voir p.1 No. 20)

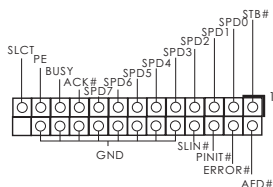

All s'agit d'une interface pour le câble du port d'impression, qui permet le raccordement pratique de périphériques d'impression.

Embase TPM
 (TPMS1 à 17 broches)
 (voir p.1, No. 19)

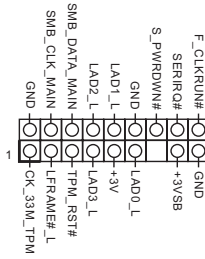

Ce connecteur prend en charge un module TPM (Trusted Platform Module – Module de plateforme sécurisée), qui permet de sauvegarder clés, certificats numériques, mots de passe et données en toute sécurité. Le système TPM permet également de renforcer la sécurité du réseau, de protéger les identités numériques et de préserver l'intégrité de la plateforme.

1. Introduzione

Grazie per aver scelto una scheda madre ASRock **FM2A58M+ BTC**, una scheda madre affidabile prodotta secondo i severi criteri di qualità ASRock. Le prestazioni eccellenti e il design robusto si conformano all'impegno di ASRock nella ricerca della qualità e della resistenza.

Questa Guida Rapida all'Installazione contiene l'introduzione alla motherboard e la guida passo-passo all'installazione. Informazioni più dettagliate sulla motherboard si possono trovare nel manuale per l'utente presente nel CD di supporto.



Le specifiche della scheda madre e il software del BIOS possono essere aggiornati, pertanto il contenuto di questo manuale può subire variazioni senza preavviso. Nel caso in cui questo manuale sia modificato, la versione aggiornata sarà disponibile sul sito di ASRock senza altro avviso. Sul sito ASRock si possono anche trovare le più recenti schede VGA e gli elenchi di CPU supportate.

ASRock website <http://www.asrock.com>

Se si necessita dell'assistenza tecnica per questa scheda madre, visitare il nostro sito per informazioni specifiche sul modello che si sta usando.

www.asrock.com/support/index.asp

1.1 Contenuto della confezione

Scheda madre ASRock **FM2A58M+ BTC** (ATX Form Factor)

Guida di installazione rapida ASRock **FM2A58M+ BTC**

CD di supporto ASRock **FM2A58M+ BTC**

Due cavi dati Serial ATA (SATA) (opzionali)

Un I/O Shield

1.2 Specifiche

- Piattaforma**
- Fattore di forma Micro ATX
 - Design condensatore compatto
 - Circuito in vetro ad alta densità

- Processore**
- Supporto per processori socket FM2+ 95W / FM2 100W
 - Struttura di fase con alimentazione 4 + 2

- Chipset**
- AMD A58 FCH (Bolton-D2)

- Memoria**
- Supporto tecnologia Dual Channel Memory
 - 2 x slot DDR3 DIMM
 - Supporto DDR3 1866/1600/ 1333/1066 non-ECC, memoria senza buffer
 - Capacità massima della memoria di sistema: 32GB
 - Supporto di Intel® XMP (Extreme Memory Profile) 1.3/1.2
 - Supporta tecnologia AMD Memory Profile (AMP)
 - Contatti d'oro 15µ negli alloggi DIMM

- Slot di espansione**
- 1 x slot PCI Express 3.0 x16 (PCIe1: modalità x16)
* PCIe 3.0 è supportato solo con CPU FM2+. Con CPU FM2, supporta solo PCIe 2.0.
 - 3 x slot PCI Express 2.0 x1
 - Contatti d'oro 15µ nell'alloggio VGA PCIe (PCIe1)

- VGA su scheda**
- Grafica serie AMD Radeon™ R7/R5 integrata in APU serie A
 - DirectX 11.1, Pixel Shader 5.0 con CPU FM2+. DirectX 11, Pixel Shader 5.0 con CPU FM2.
 - Memoria massima condivisa 2GB
 - Uscita VGA Doppia: supporto porte DVI-D e D-Sub tramite veri catodi display indipendente
 - Supporta Dual-link DVI-D con risoluzione massima fino a 2560x1600 @ 60Hz
 - Supporta D-Sub con risoluzione massima fino a 1920x1200 @ 60Hz

- Supporta AMD Steady Video™ 2.0: Nuova capacità di post-elaborazione video per la riduzione automatica delle vibrazioni nei video a casa/on-line
- Supporto della funzione HDCP con le porte DVI-D
- Supporto 1080p Blu-ray (BD) / HD-DVD riproduzione con le porte DVI-D

Audio

- 5.1 CH HD Audio (Realtek ALC662 Audio Codec)
- Supporto protezione da sovratensione (protezione completa ASRock dai picchi di corrente)
- TI® NE5532 (supporta l'amplificatore per cuffie di qualità superiore fino a 600 Ohm) (Line-Out solo su I/O posteriore)

LAN

- PCIE x1 Gigabit LAN 10/100/1000 Mb/s
- Realtek RTL8111GR
- Supporta Wake-On-WAN
- Supporta Wake-On-LAN
- Supporto la protezione da fulmini/scariche elettrostatiche (ESD) (protezione completa ASRock dai picchi di corrente)
- Supporta il rilevamento cavo LAN
- Supporto di Energy Efficient Ethernet 802.3az
- Supporta PXE

Pannello posteriore I/O

- 1 x porta PS/2 per mouse
- 1 x porta PS/2 per tastiera
- 1 x Porta D-Sub
- 1 x Porta DVI-D
- 6 x porte USB 2.0 già integrate (Supporto della protezione da scariche elettrostatiche (ESD) (protezione completa ASRock dai picchi di corrente))
- 1 x porte LAN RJ-45 con LED (LED azione/collegamento e LED velocità)
- Connettore HD Audio: ingresso linea / cassa frontale / microfono

Archiviazione

- 6 x connettori SATA2 3,0 Gb/s, supporto di RAID (RAID 0, RAID 1 e RAID 10) e delle funzioni NCQ, AHCI e "Hot Plug"

- Connettori**
- 1 x Collettore porta stampante
 - 1 x header TPM
 - 2 x Connettore CPU ventola (1 x 4-pin, 1 x 3-pin)
 - 2 x Connettore Chassis ventola (1 x 4-pin, 1 x 3-pin)
 - 1 x Connettore Alimentazione ventola (3-pin)
 - 1 x 24-pin collettore alimentazione ATX
 - 1 x 8-pin connettore ATX 12V
 - 1 x Connettore di alimentazione PCIe
 - 1 x Connettore audio sul pannello frontale
 - 1 x Ponticello di alimentazione USB (Potenza USB Ultra)
 - 2 x Collettore USB 2.0 (supporta 4 porte USB 2.0) (Supporto della protezione da scariche elettrostatiche (ESD) (protezione completa ASRock dai picchi di corrente))

- BIOS**
- 64Mb AMI UEFI Legal BIOS con interfaccia di supporto
 - Supporta "Plug and Play"
 - Compatibile con ACPI 1.1 wake up events
 - Supporta jumperfree
 - Supporta SMBIOS 2.3.1
 - Regolazione multi-voltaggio DRAM, CPU, SB

- CD di supporto**
- Driver, utilità, software antivirus (Versione dimostrativa), Google Chrome Browser e Toolbar, Start8 (30 giorni di prova)

- Monitoraggio-Hardware**
- Sensore per la temperatura del processore
 - Sensore temperatura scheda madre
 - Indicatore di velocità per la ventola del CPU
 - Indicatore di velocità per la ventola del Chassis
 - Ventola CPU/chassis silenziosa
 - Ventola CPU/chassis con controllo di varie velocità
 - Rilevamento CASE APERTO
 - Voltaggio: +12V, +5V, +3.3V, Vcore

- Compatibilità SO**
- Microsoft® Windows® 8.1 32 bit / 8.1 64 bit / 8 32 bit / 8 64 bit / 7 32 bit / 7 64 bit / XP 32-bit / XP 64-bit

Certificazioni

- FCC, CE, WHQL
- Predisposto ErP/EuP (è necessaria l'alimentazione predisposta per il sistema ErP/EuP)

* Per ulteriori informazioni, prego visitare il nostro sito internet:
<http://www.asrock.com>

1.3 Setup dei Jumpers

L'illustrazione mostra come sono settati i jumper. Quando il ponticello è posizionato sui pin, il jumper è "CORTOCIRCUITATO". Se sui pin non ci sono ponticelli, il jumper è "APERTO". L'illustrazione mostra un jumper a 3 pin in cui il pin1 e il pin2 sono "CORTOCIRCUITATI" quando il ponticello è posizionato su questi pin.

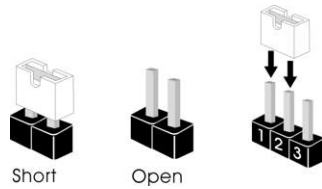

Jumper Settaggio del Jumper

Resetare la CMOS

(CLRCMOS1)
(vedi p.1item 8)



Nota: CLRCMOS1 permette di azzerare i dati nella CMOS. Per cancellare e ripristinare i parametri del sistema sulla configurazione iniziale, spegnere il computer e scollegare il cavo d'alimentazione dalla presa di corrente. Attendere 15 secondi, poi usare un cappuccio jumper per cortocircuitare il pin 2 ed il pin 3 su CLRCMOS1 per 5 secondi. Tuttavia, si consiglia di non cancellare la CMOS subito dopo avere aggiornato il BIOS. Se si deve azzerare la CMOS quando si è completato l'aggiornamento del BIOS, è necessario per prima cosa avviare il sistema e poi spegnerlo prima di eseguire l'azzeramento della CMOS. Nota che password, data, ore, profilo utente predefinito, 1394 GUID e indirizzo MAC saranno cancellati solo se è rimossa la batteria della CMOS.

Ponticello di alimentazione USB
(USB01_PWR1 a 3 pin)
(vedi p.1item 24)

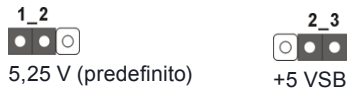

Nota:

il ponticello di alimentazione USB è stato progettato in modo specifico per utenti che utilizzano tastiere/mouse a LED. (solo per la porta USB01)

Pin 1-2 in corto (predefinito):

La tensione stabile ed l'alta corrente sono fornite per la tastiera/mouse LED .

La retroilluminazione di tastiera/mouse viene disattivata quando il PC è spento.

Pin 2-3 in corto:

La tensione +5VSB è fornita per la tastiera/mouse LED

Attivare la funzione di riattivazione di tastiera/mouse.

La retroilluminazione di tastiera/mouse viene attivata quando il PC è in modalità standby.

1.4 Collettori e Connettori su Scheda



I collettori ed i connettori su scheda NON sono dei jumper. NON installare cappucci per jumper su questi collettori e connettori. L'installazione di cappucci per jumper su questi collettori e connettori provocherà danni permanenti alla scheda madre!

Connettori Serial ATA2

(SATA_1: vedi p.1 Nr. 15)

(SATA_2: vedi p.1 Nr. 16)

(SATA_3: vedi p.1 Nr. 14)

(SATA_4: vedi p.1 Nr. 13)

(SATA_5: vedi p.1 Nr. 12)

(SATA_6: vedi p.1 Nr. 11)



Questi otto connettori Serial ATA2 (SATA2) supportano cavi dati SATA per dispositivi di immagazzinamento interni. ATA2 (SATA2) supportano cavi SATA per dispositivi di memoria interni. L'interfaccia SATA2 attuale permette velocità di trasferimento dati fino a 3.0 Gb/s.

Collettore USB 2.0

(9-pin USB45)

(vedi p.1 Nr. 17)

(9-pin USB67)

(vedi p.1 Nr. 18)

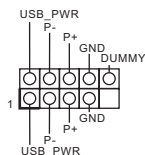

Oltre alle quattro porte USB 2.0 predefinite nel pannello I/O, la scheda madre dispone di due intestazioni USB 2.0. Ciascuna intestazione USB 2.0 supporta due porte USB 2.0.

Connettore audio sul pannello frontale

(9-pin HD_AUDIO1)

(vedi p.1 Nr. 21)

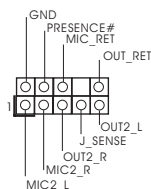

È un'interfaccia per il cavo del pannello audio. Che consente connessione facile e controllo dei dispositivi audio.



1. La caratteristica HDA (High Definition Audio) supporta il rilevamento dei connettori, però il pannello dei cavi sul telaio deve supportare la funzione HDA (High Definition Audio) per far sì che questa operi in modo corretto. Attenersi alle istruzioni del nostro manuale e del manuale del telaio per installare il sistema.
2. Se si utilizza un pannello audio AC'97, installarlo nell'installazione audio del pannello anteriore, come indicato di seguito:
 - A. Collegare Mic_IN (MIC) a MIC2_L.
 - B. Collegare Audio_R (RIN) a OUT2_R e Audio_L (LIN) ad OUT2_L.
 - C. Collegare Ground (GND) a Ground (GND).
 - D. MIC_RET e OUT_RET sono solo per il pannello audio HD. Non è necessario collegarli per il pannello audio AC'97.
 - E. Per attivare il microfono frontale.
Sistema operativo Windows® 8.1 / 8.1 64-bit / 8 / 8 64-bit / 7 / 7 64-bit / XP / XP 64-bit:
Andare alla scheda "FrontMic" (Microfono frontale) del pannello di controllo Realtek. Regolare la voce "Recording Volume" (Volume registrazione).

Collettore pannello di sistema

(9-pin PANEL1)

(vedi p.1 Nr. 10)

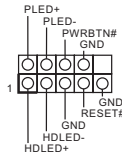

Questo collettore accomoda diverse funzioni di sistema pannello frontale.



Collegare l'interruttore d'alimentazione, l'interruttore di ripristino, l'indicatore di stato del sistema del pannello frontale del telaio a questo header in base all'assegnazione dei pin definita di seguito. Determinare i pin positivi e negativi prima di collegare i cavi.

PWRBTN (interruttore d'alimentazione):

Va collegato all'interruttore d'alimentazione del pannello frontale del telaio. Usando l'interruttore d'alimentazione si può configurare il modo in cui si spegne il sistema.

RESET (interruttore di ripristino):

Va collegato all'interruttore di ripristino del pannello frontale del telaio. Premere l'interruttore di ripristino per riavviare il sistema se il computer si blocca e non riesce ad eseguire un normale riavvio.

PLED (LED alimentazione del sistema):

Va collegato all'indicatore di stato d'alimentazione del pannello frontale del telaio. Il LED è acceso quando il sistema è operativo. Il LED continua a lampeggiare quando il sistema è in stato di standby S1. Il LED è spento quando il sistema è in stato di sospensione /ibernazione S3/S4 oppure spento (S5).

HDLED (LED attività disco rigido):

Va collegato al LED attività disco rigido del pannello frontale del telaio. Il LED è acceso quando disco rigido legge e scrive i dati.

Il design del pannello frontale può variare in base ai telai. Il modulo di un pannello frontale può consistere di: interruttore d'alimentazione, interruttore di ripristino, LED d'alimentazione, LED attività disco rigido, casse, eccetera. Quando si collega il modulo del pannello frontale a questo header, assicurarsi che l'assegnazione dei fili e dei pin sia fatta corrispondere in modo appropriato.

Collettore casse telaio

(4-pin SPEAKER1)

(vedi p.1 Nr. 9)

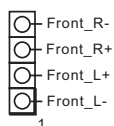

Collegare le casse del telaio a questo collettore.

Collettori Chassis ed alimentazione ventola

(4-pin CHA_FAN1)

(vedi p.1 Nr. 7)

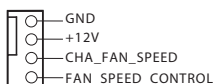

Collegare i cavi della ventola ai corrispondenti connettori facendo combaciare il cavo nero col pin di terra.

(3-pin CHA_FAN2)

(vedi p.1 Nr. 23)

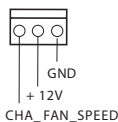

(3-pin PWR_FAN1)

(vedi p.1 Nr. 2)

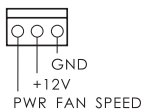

Connettore ventolina CPU

(4-pin CPU_FAN1)

(vedi p.1 Nr. 3)

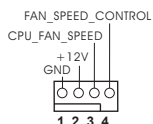

Collegare il cavo della ventolina CPU a questo connettore e far combaciare il filo nero al pin terra.



Sebbene la presente scheda madre disponga di un supporto per ventola CPU a 4 piedini (ventola silenziosa), la ventola CPU a 3 piedini è in grado di funzionare anche senza la funzione di controllo della velocità della ventola. Se si intende collegare la ventola CPU a 3 piedini al connettore della ventola CPU su questa scheda madre, collegarla ai piedini 1-3.

Piedini 1-3 collegati ←

Installazione della ventola a 3 piedini



(3-pin CPU_FAN2)
(vedi p.1 Nr. 4)

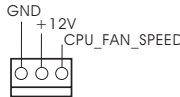

Connettore alimentazione ATX

(24-pin ATXPWR1)
(vedi p.1 Nr. 6)

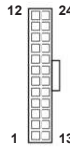

Collegare la sorgente d'alimentazione ATX a questo connettore.



Con questa scheda madre, c'è in dotazione un connettore elettrico ATX a 24 pin, ma può funzionare lo stesso se si adotta un alimentatore ATX a 20 pin. Per usare l'alimentatore ATX a 20 pin, collegare l'alimentatore con il Pin 1 e il Pin 13.

Installazione dell'alimentatore ATX a 20 pin



Connettore ATX 12 V

(8-pin ATX12V1)
(vedi p.1 Nr. 1)

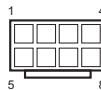

Collegare un alimentatore ATX 12 V a questo connettore.



Sebbene questa schedamadre fornisca un connettore elettrico 8-pin ATX 12V, l'unità può ancora essere funzionante se viene utilizzata una fornitura elettrica tradizionale a 4-pin ATX 12V. Per usare tale fornitura elettrica 4-pin ATX 12V, prego collegare la presa elettrica al Pin 1 e Pin 5.

Installazione elettrica 4-Pin ATX 12V



Connettore di alimentazione PCIe
(PCIE_PWR1 a 4 pin)
(see p.1, No. 22)



Collegare a questo connettore un cavo di alimentazione Molex a 4 pin quando sono installate più di tre schede grafiche.

Embase de port d'impression

(LPT1 25 broches)

(voir p.1 No. 20)

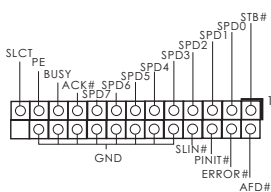

All s'agit d'une interface pour le câble du port d'impression, qui permet le raccordement pratique de périphériques d'impression.

Header TPM

(TPMS1 a 17 pin)

(vedere pag. 1, n. 19)

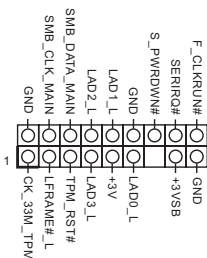

Questo connettore supporta il sistema Trusted Platform Module (TPM), che può archiviare in modo sicuro chiavi, certificati digitali, password e dati. Un sistema TPM permette anche di potenziare la sicurezza della rete, di proteggere identità digitali e di garantire l'integrità della piattaforma.

1. Introducción

Gracias por su compra de ASRock **FM2A58M+ BTC** placa madre, una placa de confianza producida bajo el control de calidad estricto y persistente. La placa madre provee realización excelente con un diseño robusto conforme al compromiso de calidad y resistencia de ASRock.

Esta Guía rápida de instalación contiene una introducción a la placa base y una guía de instalación paso a paso. Puede encontrar una información más detallada sobre la placa base en el manual de usuario incluido en el CD de soporte.



Porque las especificaciones de la placa madre y el software de BIOS podrían ser actualizados, el contenido de este manual puede ser cambiado sin aviso. En caso de cualquier modificación de este manual, la versión actualizada estará disponible en el website de ASRock sin previo aviso. También encontrará las listas de las últimas tarjetas VGA y CPU soportadas en la página web de ASRock.

Website de ASRock <http://www.asrock.com>

Si necesita asistencia técnica en relación con esta placa base, visite nuestra página web con el número de modelo específico de su placa. www.asrock.com/support/index.asp

1.1 Contenido de la caja

Placa base ASRock **FM2A58M+ BTC** (Factor forma ATX)

Guía de instalación rápida de ASRock **FM2A58M+ BTC**

CD de soporte de ASRock **FM2A58M+ BTC**

Dos cables de datos Serial ATA (SATA) (Opcional)

Una protección I/O

1.2 Especificación

- Plataforma**
- Factor de forma Micro ATX
 - Todo diseño de Capacitor Sólido
 - PCB de fibra de vidrio de alta densidad

- Procesador**
- Admite zócalos de procesadores FM2+ 95W / FM2 100W
 - Diseño de fases de potencia 4 + 2

- Chipset**
- AMD A58 FCH (Bolton-D2)

- Memoria**
- Soporte de Tecnología de Memoria de Doble Canal
 - 2 x DDR3 DIMM slots
 - Apoya DDR3 1866/1600/1333/1066 non-ECC, memoria de un-buffered
 - Máxima capacidad de la memoria del sistema: 32GB
 - Compatible con Intel® Extreme Memory Profile (XMP)1.3/1.2
 - Admite tecnología de perfil de memoria AMD (AMP, Memory Profile Technology)
 - Contacto de oro de 15µ en las ranuras DIMM

- Ranuras de Expansión**
- 1 x ranuras PCI Express 3.0 x16 (PCIE1: modo x16)
 - * Solo se admite PCIE 3.0 con FM2+ CPU. Con FM2 CPU, solo se admite PCIE 2.0.
 - 3 x ranuras PCI Express 2.0 x1
 - Contacto de oro de 15µ en la ranura VGA PCIe (PCIE1)

- VGA On-Board**
- Gráficos integrados de serie R7/R5, HD AMD Radeon™ con APU de serie A
 - DirectX 11.1, Sombreador de píxeles 5.0 con FM2+ CPU. DirectX 11, Sombreador de píxeles 5.0 con FM2 CPU.
 - 2GB de Memoria máxima compartida
 - Salida de VGA dual: apoya los puertos de DVI-D y de D-Sub por los reguladores independientes de la exhibición

- Admite Dual-link DVI-D con una resolución máxima de 2560x1600 a 60 Hz
- Admite D-Sub con una resolución máxima de 1920x1200 a 60 Hz
- Admite AMD Steady Video™ 2.0: Nueva capacidad de procesamiento de vídeo para reducción automática de oscilaciones en vídeo doméstico y en línea
- Admite la función HDCP con puertos DVI-D
- Apoya la reproducción de Blu-ray de 1080p (BD) / HD-DVD con puertos DVI-D

Audio

- 5.1 CH HD Audio (Realtek ALC662 Audio Codec)
- Admite protección contra subidas de tensión (Protección Integral contra Picos de ASRock)
- TI® NE5532 (compatible con Amplificador de Auriculares Premium de hasta 600 ohmios) (Línea de salida solamente en el E/S posterior)

LAN

- PCIE x1 Gigabit LAN 10/100/1000 Mb/s
- Realtek RTL8111GR
- Admite Reactivación en WAN
- Admite Reactivación en LAN
- Admite Protección Total Contra Picos de Tensión
- Admite detección de conexión de cable LAN
- Compatible con Ethernet 802.3az de bajo consumo energético
- Compatible con PXE

Entrada/ Salida de Panel Trasero

- 1 x puerto de ratón PS/2
- 1 x puerto de teclado PS/2
- 1 x Puerto D-Sub
- 1 x Puerto DVI-D
- 6 x puertos USB 2.0 predeterminados (Admite protección ESD (Protección Integral contra Picos de ASRock))
- 1 x Puerto LAN RJ-45 con LED (LED de ACCIÓN/ ENLACE y LED de VELOCIDAD)
- Conexión de audio: Entrada de línea / Altavoz frontal / Micrófono

Almacenamiento

- 6 x conectores SATA2 de 3,0 Gb/s compatibles con funciones RAID (RAID 0, RAID 1 y RAID 10), NCQ, AHCI y de “conexión en caliente” compatibles con funciones NCQ, AHCI y de “conexión en caliente”

Conectores

- 1 x cabecera de puerto de impresora
- 1 cabezal TPM
- 2 x Conectores de ventilador de la CPU (1 x 4-pin, 1 x 3-pin)
- 2 x Conectores de ventilador del chasis (1 x 4-pin, 1 x 3-pin)
- 1 x Conector de ventilador de alimentación (3-pin)
- 1 x 24-pin cabezal de alimentación ATX
- 1 x 8-pin conector de ATX 12V power
- 1 x Conector de alimentación PCIe
- 1 x Conector de audio de panel frontal
- 1 x Puente de alimentación USB (Ultra Alimentación por USB)
- 2 x Cabezal USB 2.0 (admite 4 puertos USB 2.0 adicionales) (Admite protección ESD (Protección Integral contra Picos de ASRock))

BIOS

- 64Mb AMI BIOS legal UEFI AMI compatible con GUI
- Soporta “Plug and Play”
- ACPI 1.1 compliance wake up events
- Soporta “jumper free setup”
- Soporta SMBIOS 2.3.1
- Múltiple ajuste de DRAM, CPU, SB Voltage

CD de soporte

- Controladores, Utilerías, Software de Anti Virus (Versión de prueba), Google Chrome Browser y Toolbar, Start8 (Versión de prueba de 30 días)

Monitor Hardware

- Sensibilidad a la temperatura del procesador
- Sensibilidad a la temperatura de la placa madre
- Taquímetros de los ventiladores del procesador y del CPU

- Taquímetros de los ventiladores del procesador y del chasis
- Ventilador silencioso del CPU y el chasis
- Control de ajuste de la velocidad del ventilador de la CPU y el chasis
- Monitor de Voltaje: +12V, +5V, +3.3V, Vcore

OS

- En conformidad con Microsoft® Windows® 8.1 32 bits / 8.1 64 bits / 8 32 bits / 8 64 bits / 7 32 bits / 7 64 bits / XP 32-bit / XP 64-bit

Certificaciones





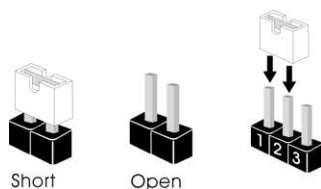

- FCC, CE, WHQL
- Cumple con la directiva ErP/EuP (se requiere una fuente de alimentación que cumpla con la directiva ErP/EuP)

* Para más información sobre los productos, por favor visite nuestro sitio web:
<http://www.asrock.com>







1.3 Setup de Jumpers

La ilustración muestra como los jumpers son configurados. Cuando haya un jumper-cap sobre los pins, se dice que el jumper está "Short". No habiendo jumper cap sobre los pins, el jumper está "Open". La ilustración muestra un jumper de 3 pins cuyo pin 1 y pin 2 están "Short".



Jumper	Setting				
Limpiar CMOS (CLRCMOS1, jumper de 3 pins) (ver p.1, No. 8)	<table border="0"><tr><td style="text-align: center;">1_2 </td><td style="text-align: center;">2_3 </td></tr><tr><td style="text-align: center;">Valor predeterminado</td><td style="text-align: center;">Restablecimiento de la CMOS</td></tr></table>	1_2 	2_3 	Valor predeterminado	Restablecimiento de la CMOS
1_2 	2_3 				
Valor predeterminado	Restablecimiento de la CMOS				

Nota: CLRCMOS1 permite borrar los datos de la memoria CMOS. Para borrar los parámetros del sistema y restablecer la configuración predeterminada de los mismos, apague el equipo y desenchufe el cable de alimentación de la toma de corriente eléctrica. Deje que transcurran 15 segundos y, después, utilice un puente para cortocircuitar los contactos 2 y 3 de CLRCMOS1 durante 5 segundos. No borre la memoria CMOS justamente después de actualizar el BIOS. Si necesita borrar la memoria CMOS justamente después de actualizar el BIOS, debe iniciar primero el sistema y, a continuación, cerrarlo antes de llevar a cabo el borrado de dicha memoria. Tenga en cuenta que la contraseña, la fecha, la hora, el perfil predeterminado del usuario, el GUID 1394 y la dirección MAC solamente se borrarán si la batería CMOS se quita.

Puente de alimentación USB (USB01_PWR1 de 3 pines) (ver p.1, No. 24)	<table border="0"><tr><td style="text-align: center;">1_2 </td><td style="text-align: center;">2_3 </td></tr><tr><td style="text-align: center;">+5V (Predeterminado)</td><td style="text-align: center;">+5VSB</td></tr></table>	1_2 	2_3 	+5V (Predeterminado)	+5VSB
1_2 	2_3 				
+5V (Predeterminado)	+5VSB				

Nota:

El Puente de alimentación USB está diseñado específicamente para los usuarios que utilizan un teclado/ratón LED. (sólo para el puerto USB01)

Pin 1-2 cerrado (predeterminado):

Se proporcionan tensión estable y alta corriente para el teclado / ratón LED.

La retroiluminación de su teclado/ratón será apagado cuando el PC está apagado.

Pin 2-3 cerrado:

Se proporciona una tensión de +5VSB para el teclado / ratón LED.

La función de reactivación de su teclado/ratón será activada.

La retroiluminación de su teclado/ratón será encendido cuando el PC está en modo de espera.

1.4 Cabezales y Conectores en Placas



Los conectores y cabezales en placa NO son puentes. NO coloque las cubiertas de los puentes sobre estos cabezales y conectores. El colocar cubiertas de puentes sobre los conectores y cabezales provocará un daño permanente en la placa base.

Conexiones de serie ATA2

(SATA_1: vea p.1, N. 15)
 (SATA_2: vea p.1, N. 16)
 (SATA_3: vea p.1, N. 14)
 (SATA_4: vea p.1, N. 13)
 (SATA_5: vea p.1, N. 12)
 (SATA_6: vea p.1, N. 11)



Estas seis conexiones de serie ATA2 (SATA2) admiten cables SATA para dispositivos de almacenamiento internos. La interfaz SATA2 actual permite una velocidad de transferencia de 3.0 Gb/s.

Cabezal USB 2.0

(9-pin USB45)
 (vea p.1, N. 17)
 (9-pin USB67)
 (vea p.1, N. 18)

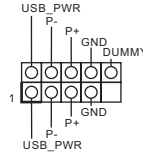

Además de seis puertos USB 2.0 predeterminados en el panel de E/S, hay dos bases de conexiones USB 2.0 en esta placa base. Cada una de estas bases de conexiones admite dos puertos USB 2.0.

Conector de audio de panel frontal

(9-pin HD_AUDIO1)
 (vea p.1, N. 21)

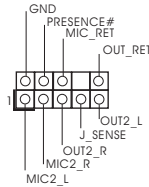

Este es una interface para cable de audio de panel frontal que permite conexión y control conveniente de aparatos de Audio.



1. El Audio de Alta Definición soporta la detección de conector, pero el cable de panel en el chasis debe soportar HDA para operar correctamente. Por favor, siga las instrucciones en nuestro manual y en el manual de chasis para instalar su sistema.
2. Si utiliza el panel de sonido AC'97, instálelo en la cabecera de sonido del panel frontal de la siguiente manera:
 - A. Conecte Mic_IN (MIC) a MIC2_L.
 - B. Conecte Audio_R (RIN) a OUT2_R y Audio_L (LIN) en OUT2_L.
 - C. Conecte Ground (GND) a Ground (GND).
 - D. MIC_RET y OUT_RET son sólo para el panel de sonido HD. No necesitará conectarlos al panel de sonido AC'97.

E. Activación del micrófono frontal.

En sistemas operativos Windows® 8.1 / 8.1 64-bit / 8 / 8 64-bit / 7 / 7 64-bit / XP / XP 64-bit: Acceda a la ficha "FrontMic" (Micrófono frontal) del panel de control Realtek. Ajuste la posición del control deslizante "Recording Volume" (Volumen de grabación).

Cabezal de panel de sistema

(9-pin PANEL1)

(vea p.1, N. 10)

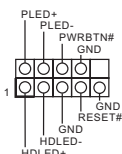

Este cabezar acomoda varias funciones de panel frontal de sistema.

Conecte el interruptor de alimentación, el interruptor de restablecimiento y el indicador de estado del sistema situados en el chasis con esta cabecera en función de las siguientes asignaciones de contacto. Preste atención a los contactos positivos y negativos antes de conectar los cables.

PWRBTN (interruptor de alimentación):

Conecte el interruptor de encendido situado en el panel frontal del chasis. Puede configurar la forma de apagar su sistema mediante el interruptor de alimentación.

REESTABLECER (interruptor de restablecimiento):

Conecte el interruptor de restablecimiento situado en el panel frontal del chasis. Pulse el interruptor de restablecimiento para restablecer el equipo si se bloquea y no se reinicia con normalidad.

PLED (LED de alimentación del sistema):

Conecte el indicador de estado de alimentación situado en el panel frontal del chasis. El LED se enciende cuando el sistema esté en funcionamiento. El LED parpadea cuando el sistema se encuentre en estado de suspensión S1. El LED se apaga cuando el sistema se encuentre en estado de suspensión S3/S4 o se apaga (S5).

HDLED (LED de actividad del disco duro):

Conecte el LED de actividad de disco duro situado en el panel frontal del chasis. El LED se enciende cuando el disco duro esté leyendo o escribiendo datos.

Es posible que el diseño del panel frontal varíe en función del chasis. Un módulo del panel frontal consiste principalmente de interruptor de alimentación, interruptor de restablecimiento, LED de alimentación, LED de actividad del disco duro, altavoz, etc. Al conectar el módulo del panel frontal del chasis a esta cabecera, asegúrese de que las asignaciones de cables y las asignaciones de contactos coincidan correctamente.

Cabezal del altavoz del chasis
(4-pin SPEAKER1)
(vea p.1, N. 9)

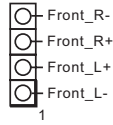

Conecte el altavoz del chasis a su cabezal.

Conectores de ventilador de chasis y alimentación
(4-pin CHA_FAN1)
(vea p.1, N. 7)

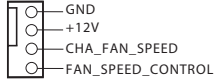

Por favor, conecte los cables del ventilador a los conectores de ventilador, haciendo coincidir el cable negro con la patilla de masa.

(3-pin CHA_FAN2)
(vea p.1, N. 23)

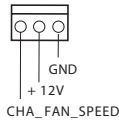

(3-pin PWR_FAN1)
(vea p.1, N. 2)

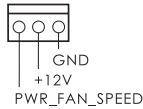

Conector del ventilador de la CPU
(4-pin CPU_FAN1)
(vea p.1, N. 3)

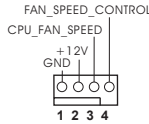

Conecte el cable del ventilador de la CPU a este conector y haga coincidir el cable negro con el conector de tierra.



Aunque esta placa base proporciona compatibilidad para un ventilador (silencioso) de procesador de 4 contactos, el ventilador de procesador de 3 contactos seguirá funcionando correctamente incluso sin la función de control de velocidad del ventilador. Si pretende enchufar el ventilador de procesador de 3 contactos en el conector del ventilador de procesador de esta placa base, conéctelo al contacto 1-3.

Contacto 1-3 conectado ←

Instalación del ventilador de 3 contactos



(3-pin CPU_FAN2)
(vea p.1, N. 4)

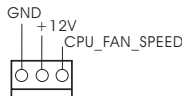

Cabezal de alimentación ATX

(24-pin ATXPWR1)

(vea p.1, N. 6)

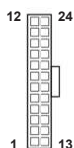

Conecte la fuente de alimentación ATX a su cabezal.



A pesar de que esta placa base incluye un conector de alimentación ATX de 24 pines, ésta puede funcionar incluso si utiliza una fuente de alimentación ATX de 20 pines tradicional. Para usar una fuente de alimentación ATX de 20 pines, por favor, conecte su fuente de alimentación usando los Pines 1 y 13.

Instalación de una Fuente de Alimentación ATX de 20 Pines



Conector de ATX 12V power

(8-pin ATX12V1)

(vea p.1, N. 1)

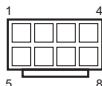

Tenga en cuenta que es necesario conectar este conector a una toma de corriente con el enchufe ATX 12V, de modo que proporcione suficiente electricidad. De lo contrario no se podrá encender.



Aunque esta placa base proporciona un conector de energía de 8-pin ATX 12V, puede todavía trabajar si usted adopta un fuente tradicional de energía de 4-pin ATX 12V. Para usar el fuente de energía de 4-pin ATX 12V, por favor conecte su fuente de energía junto con Pin 1 y Pin 5.

Instalación de Fuente de Energía de 4-Pin ATX 12V



Conector de alimentación PCIe

(PCI_E_PWR1 de 4 pines)

(see p.1, No. 22)



Conecte el cable de alimentación Molex de 4 pines cuando se instalan más de tres tarjetas gráficas.

Cabecera de puerto de impresora

(LPT1 de 25 terminales)

(vea p.1, N. 20)

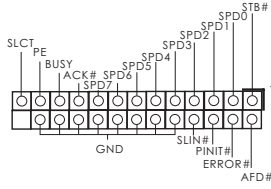

Esta es una interfaz de puerto para cable de impresora que permite conectar cómodamente dispositivos de impresión.

Cabezal TPM

(TPMS1 de 17 pines)

(vea p.1, N. 19)

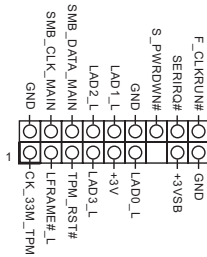

Este conector es compatible con el sistema Módulo de Plataforma Segura (TPM, en inglés), que puede almacenar de forma segura claves, certificados digitales, contraseñas y datos. Un sistema TPM también ayuda a aumentar la seguridad en la red, protege las identidades digitales y garantiza la integridad de la plataforma.

1. Введение

Благодарим вас за покупку материнской платы ASRock **FM2A58M+ BTC** надежной материнской платы, изготовленной в соответствии с постоянно предъявляемыми ASRock жесткими требованиями к качеству. Она обеспечивает превосходную производительность и отличается отличной конструкцией, которые отражают приверженность ASRock качеству и долговечности.

Данное руководство по быстрой установке включает вводную информацию о материнской плате и пошаговые инструкции по ее установке. Более подробные сведения о плате можно найти в руководстве пользователя на компакт-диске поддержки.



Спецификации материнской платы и программное обеспечение BIOS иногда изменяются, поэтому содержание этого руководства может обновляться без уведомления. В случае любых модификаций руководства его новая версия будет размещена на веб-сайте ASRock без специального уведомления. Кроме того, самые свежие списки поддерживаемых модулей памяти и процессоров можно найти на сайте ASRock.

Адрес веб-сайта ASRock <http://www.asrock.com>

При необходимости технической поддержки по вопросам данной материнской платы посетите наш веб-сайт для получения информации об используемой модели.

www.asrock.com/support/index.asp

1.1 Комплектность

Материнская плата ASRock **FM2A58M+ BTC** (форм-фактор ATX)

Руководство по быстрой установке ASRock **FM2A58M+ BTC**

Компакт-диск поддержки ASRock **FM2A58M+ BTC**

2 x кабель данных Serial ATA (SATA) (дополнительно)

1 x I/O Щит Группы ввода / вывода

1.2 Спецификации

Платформа	<ul style="list-style-type: none"> • Форм-фактор Micro ATX • Весь Твердый Конденсаторный проект • High Density Glass Fabric PCB
Процессор	<ul style="list-style-type: none"> • Поддержка разъема FM2+ 95 Вт / процессоров FM2 100 Вт • Технология 4 + 2 Power Phase Design
Набор микросхем	<ul style="list-style-type: none"> • AMD A58 FCH (Bolton-D2)
Память	<ul style="list-style-type: none"> • Поддержка технологии Dual Channel DDR3 Memory Technology • 2 x гнезда DDR3 DIMM • Поддержите DDR3 1866/1600/1333/1066 не-ЕСС, безбуферная память 1066/800 не-ЕСС, безбуферная память • Макс. 32 Гб • поддержка профиля Intel® Extreme Memory Profile (XMP) 1.3/1.2 • Поддержка технологии AMD Memory Profile (AMP) • Разъемы DIMM с позолоченными контактами 15μ
Гнезда расширения	<ul style="list-style-type: none"> • 1 x слота PCI Express 3.0 x16 (PCIЕ1: режим x16) * PCIЕ 3.0 поддерживается только с процессором FM2+. Спроцессором FM2 поддерживается только PCIЕ 2.0. • 3 x гнезда PCI Express 2.0 x1 • Разъем VGA PCIe (PCIЕ1) с позолоченными контактами 15μ

Графика

- Видеоадаптер AMD Radeon™ R7/R5
Поддержка
- DirectX 11.1, Pixel Shader 5.0 с процессором FM2+. DirectX 11, Pixel Shader 5.0 с процессором FM2.
- Двойственное VGA выходное устройство: поддерживает DVI-D и D-Sub порты через независимый контроллер дисплея
- Поддержка Dual-link DVI-D с максимальным разрешением до 2560x1600 @ 60 Гц
- Поддержка D-Sub с максимальным разрешением до 1920x1200 @ 60 Гц
- Поддержка технологии AMD Steady Video™ 2.0: новая функция постобработки видеоизображения для автоматического устранения дрожания при просмотре домашних и онлайн-видеозаписей
- Поддержка функции HDCP через разъемы DVI-D
- Поддержат Blu-луч 1080p (КОММУТАЦИОННАЯ ДОСКА) / воспроизведение HD-DVD через разъемы DVI-D

Аудиосистема

- 5.1 CH HD Аудио HD (Кодер-декодер Аудио Realtek ALC662)
- Поддержка защиты от перенапряжений (Полная защита (ASRock от выбросов напряжения))
- TI® NE5532 (поддержка усилителя Premium Headset Amplifier до 600 Ом)

ЛВС

- PCIE x 1 Gigabit LAN 10/100/1000 Mb/s
- Realtek RTL8111GR
- поддержка Wake-On-WAN
- поддержка Wake-On-LAN
- (Поддержка защиты от молнии/ электростатического электричества (Полная защита (ASRock от выбросов напряжения))

- Поддержка определения кабеля ЛВС
- Поддержка энергосберегающего интерфейса Ethernet 802.3az
- Поддержка PXE

Разъемы ввода-вывода на задней

- 1 x порт мыши PS/2
- 1 x порт клавиатуры PS/2
- 1 x D-Sub порт
- 1 x DVI-D порт
- 6 x порта USB 2.0 на задней панели в стандартной конфигурации (Поддержка защиты от электростатического электричества (Полная защита (ASRock от выбросов напряжения))
- Разъем 1 x RJ-45 LAN с светодиодным индикатором (индикатор ACT/LINK и индикатор SPEED)
- Соединитель звуковой подсистемы: линейный вход / передняя колонка / микрофон

Запоминающие устройства

- 6 x разъема SATA2 3,0 Гбит/с, поддержка функций RAID (RAID 0, устройства RAID 1 и RAID 10), NCQ, AHCI и «горячего подключения»

Колодки и плате

- 1 x Разъем порта печати
- 1 x колодка TPM
- 2 x разъем для вентилятора ЦП (1 x 4-контактный, 1 x 3-контактный)
- 2 x разъема для вентилятора корпуса (1 x 4-контактный, 1 x 3-контактный)
- 1 x соединитель Power FAN (3-контактный)
- 1 x 24-контактный Колодка питания ATX
- 1 x 8-контактный Разъем ATX 12 В
- 1 разъем питания PCIe
- 1 x Аудиоразъем передней панели
- 1 переключатель питания USB (Источник питания Ultra USB)s

- 2 x Колодка USB 2.0 (одна колодка для поддержки 4 дополнительных портов USB 2.0 (Поддержка защиты от электростатического электричества (Полная защита (ASRock от выбросов напряжения))

BIOS

- 64Mb AMI UEFI Legal BIOS с поддержкой графического интерфейса поль зователя
- поддержка “Plug and Play”
- ACPI 1.1, включение по событиям
- поддержка режима настройки без перемычек
- поддержка SMBIOS 2.3.1
- Регулировка напряжений DRAM, CPU, SB

Компактдиск поддержки

- Драйверы, Утилиты, Антивирус (пробная версия), Google Chrome Browser и Toolbar, Start8 (демоверсия на 30 дней)

Контроль оборудования

- Датчики температуры процессора
- Датчики температуры корпуса
- Тахометры вентиляторов ЦП FAN
- Тахометры вентиляторов Шасси FAN
- Бесшумный вентилятор ЦП/Шасси блока

Контроль оборудования

- Датчики температуры процессора
- Датчики температуры корпуса
- Тахометры вентиляторов ЦП FAN
- Тахометры вентиляторов Шасси FAN
- Бесшумный вентилятор ЦП/Шасси блока
- Мультиконтроль скорости вентилятора ЦП/Шасси
- Контроль напряжения: +12V, +5V, +3.3V, Vcore

Операцион

- Совместимость с Microsoft® Windows® 8.1 32-bit / 8.1 64-bit / 8 32-bit / 8 64-bit / 7 32-bit / 7 64-bit / XP 32-bit / XP 64-bit

**ные системы
Сертификаты**

- FCC, CE, WHQL
- Совместимость с ErP/EuP Ready (требуется блок питания совместимый с ErP/EuP)

* Для детальной информации продукта, пожалуйста посетите наш вебсайт:
<http://www.asrock.com>

1.3 Установка переключателей

Конфигурация переключателей иллюстрируется на рисунке. Когда переключатель надет на контакты, они называются “замкнутыми” (short). Если на контактах переключателя нет, то они называются “разомкнутыми” (open). На иллюстрации показана 3-контактная переключатель, у которой контакты 1 и 2 замкнуты.

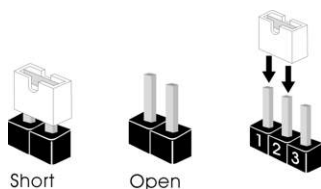

Переключатель	Установка	Описание
---------------	-----------	----------

Очистка CMOS

(CLRCMOS1,
3-контактная переключатель)
(см. стр. 1, п. 8)



Примечание. Контактная колодка CLRCMOS1 позволяет очистить данные CMOS. Для очистки данных и восстановления заводских системных параметров сначала выключите компьютер и отсоедините сетевую вилку кабеля питания от электророзетки. Выждите не менее 15 секунд и колпачковой переключатель на 5 секунд переключите штырьки 2 и 3 контактной колодки CLRCMOS1. Однако не производите очистку CMOS непосредственно после обновления BIOS. Если необходимо очистить CMOS сразу же после окончания обновления BIOS, то, перед очисткой CMOS, необходимо сначала выполнить загрузку системы, а затем завершить ее работу. Примите во внимание, что пароль, дата, время, профиль пользователя по умолчанию, идентификатор 1394 GUID и MAC-адрес будут очищены только тогда, когда будет извлечена из своего гнезда батарейка CMOS.

Переключатель питания
USB
(3-контактная, USB01_PWR1)
(см. стр. 1, п. 24)



Примечание:
переключатель питания USB предназначена для пользователей, использующих клавиатуру (мышь) с подсветкой. (только для USB01 порта)

Замкнуты контакты 1 и 2 (по умолчанию)

Для светодиодной клавиатуры/мыши обеспечивается устойчивое высокое напряжение. При выключенном ПК подсветка клавиатуры (мыши) будет ВЫКЛЮЧЕНА.

Замкнуты контакты 2 и 3

Для светодиодной клавиатуры/мыши обеспечивается напряжение +5VSB. Включена функция пробуждения с помощью клавиатуры (мыши). При нахождении ПК в режиме ожидания подсветка клавиатуры (мыши) будет ВКЛЮЧЕНА.

1.4 Колодки и разъемы на плате



Имеющиеся на плате колодки и разъемы НЕ ЯВЛЯЮТСЯ контактами для перемычек. НЕ УСТАНАВЛИВАЙТЕ перемычки на эти колодки и разъемы – это приведет к необратимому повреждению материнской платы!

Разъемы Serial ATA2

(SATA_1, см. стр. 1, п. 15)

(SATA_2, см. стр. 1, п. 16)

(SATA_3, см. стр. 1, п. 14)

(SATA_4, см. стр. 1, п. 13)

(SATA_5, см. стр. 1, п. 12)

(SATA_6, см. стр. 1, п. 11)



шесть соединителя Serial ATA2 предназначены для подключения внутренних устройств хранения с использованием интерфейсных кабелей SATA2. В настоящее время интерфейс SATA допускает скорость передачи данных до \ 3,0 Гбит/с.

Колодка USB 2.0

(9-контактный USB45)

(см. стр. 1, п. 17)

(9-контактный USB67)

(см. стр. 1, п. 18)

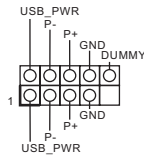

Помимо шести стандартных портов USB 2.0 на панели ввода-вывода, на данной материнской плате предусмотрено два разъема USB 2.0. Каждый разъем USB 2.0 поддерживает два порта USB 2.0.

Аудиоразъем передней панели

(9-контактный HD_AUDIO1)

(см. стр. 1, п. 21)

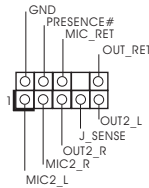

Этот интерфейс предназначен для присоединения аудиокабеля передней панели, обеспечивающего удобное подключение аудиоустройств и управление ими.



1. Система High Definition Audio поддерживает функцию автоматического обнаружения разъемов (Jack Sensing), однако для ее правильной работы кабель панели в корпусе должен поддерживать HDA. При сборке системы следуйте инструкциям, приведенным в нашем руководстве и руководстве пользователя для корпуса.
2. Если вы используете аудиопанель AC'97, подключите ее к колодке аудиоинтерфейса передней панели следующим образом:
 - A. Подключите выводы Mic_IN (MIC) к контактам MIC2_L.
 - B. Подключите выводы Audio_R (RIN) к контактам OUT2_R, а выводы Audio_L (LIN) к контактам OUT2_L.



- C. Подключите выводы Ground (GND) к контактам Ground (GND).
- D. Контакты MIC_RET и OUT_RET предназначены только для аудиопанели HD. При использовании аудиопанели AC'97 подключать их не нужно.
- E. Процедура активации микрофона приведена ниже.
Для ОС Windows® 8.1 / 8.1 64-бита / 8 / 8 64-бита / 7 / 7 64-бита / XP / XP 64-бита: Перейдите к вкладке «FrontMic» (Передний микрофон) в панели управления Realtek. Отрегулируйте уровень «Recording Volume» (Громкость записи).

Колodka системной панели
(9-контактный PANEL1)
(см. стр. 1, п. 10)

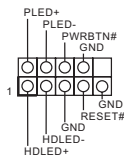

Данная колодка обеспечивает работу нескольких функций передней панели системы.



Подключите к этому разъему кнопку питания, кнопку сброса и индикатор состояния системы на корпусе в соответствии с указанным ниже назначением контактов. При подключении кабелей необходимо соблюдать полярность положительных и отрицательных контактов.

PWRBTN (кнопка питания):

Подключите к этим контактам кнопку питания на передней панели корпуса. Способ выключения системы с помощью кнопки питания можно настроить.

RESET (кнопка сброса):

Подключите к этим контактам кнопку сброса на передней панели корпуса. Нажмите кнопку сброса для перезагрузки компьютера, если компьютер «завис» и нормальную перезагрузку выполнить не удастся.

PLED (индикатор питания системы):

Подключите к этим контактам индикатор состояния питания на передней панели корпуса. Этот индикатор светится, когда система работает. Индикатор мигает, когда система находится в режиме ожидания S1. Этот индикатор не светится, когда система находится в режиме ожидания S3 или S4, либо выключена (S5).

HDLED (индикатор активности жесткого диска):

Подключите к этим контактам индикатор активности жесткого диска на передней панели корпуса. Этот индикатор светится, когда осуществляется считывание или запись данных на жестком диске.

Конструкция передней панели может различаться в зависимости от корпуса. Модуль передней панели в основном состоит из кнопки питания, кнопки сброса, индикатора питания, индикатора активности жесткого диска, динамика и т.п. При подключении к этому разъему модуля передней панели корпуса удостоверьтесь, что провода подключаются к соответствующим контактам.

Колодка динамика корпуса
(4-контактный SPEAKER1)
(см. стр. 1, п. 9)

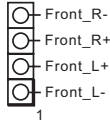

Подключите к этой колодке кабель от динамика на корпусе компьютера.

Chassis и Power Fan-соединители
(4-контактный CHA_FAN1)
(см. стр. 1, п. 7)

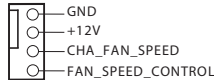

Подключите кабели вентилятора к соединителям и присоедините черный шнур к штырю заземления.

(3-контактный CHA_FAN2)
(см. стр. 1, п. 23)

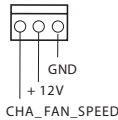

(3-контактный PWR_FAN1)
(см. стр. 1, п. 2)

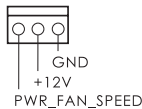

Разъем вентилятора процессора
(4-контактный CPU_FAN1)
(см. стр. 1, п. 3)

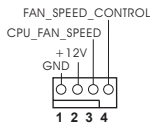

Подключите к этому разъему кабель вентилятора процессора так, чтобы черный провод соответствовал контакту земли.



Данная материнская плата поддерживает вентиляторы процессора с 4-контактным разъемом (функция тихого режима вентилятора), однако вентиляторы с 3-контактным разъемом также будут успешно работать, хотя функция управления скоростью вращения вентилятора окажется недоступной. Если вы хотите подключить вентилятор процессора с 3-контактным разъемом к разъему вентилятора процессора на данной материнской плате, для этого следует использовать контакты 1-3.

Контакты 1-3 подключены ←

Установка вентилятора с 3-контактным разъемом

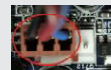

(3-контактный CPU_FAN2)
(см. стр. 1, п. 4)

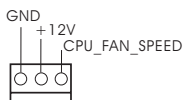

Колodka питания ATX
(24-контактный ATXPWR1)
(см. стр. 1, п. 6)

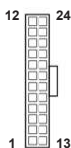

Подключите к этой колодке кабель питания ATX.



Несмотря на то, что эта материнская плата предусматривает 24-штыревой разъем питания ATX, работа будет продолжаться, даже если адаптируется традиционный 20-штыревой разъем питания ATX. Для использования 20-штыревого разъема питания ATX вставьте источник питания вместе со штекером 1 и штекером 13.

Установка 20-штыревого разъема питания ATX



Колodka питания 12V-ATX
(8-контактный ATX12V1)
(см. стр. 1, п. 1)

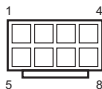

Обратите внимание, что к этому разъему необходимо подключить вилку блока питания ATX 12 В, чтобы обеспечить достаточную мощность электропитания. В противном случае включение системы будет невозможно.



Хотя эта объединительная плата обеспечивает ATX с 8 булавками 12V соединитель власти, это может все еще работать, если Вы принимаете традиционный ATX с 4-Pin 12V электропитание. Чтобы использовать электропитание ATX с 4-Pin, пожалуйста включите ваше электропитание наряду с Булавкой 1 и Прикрепите 5.

ATX C 4-Pin 12V Установка Электропитания



Разъем питания PCIe
 (4-контактный, PCIE_PWR1)
 (see p.1, No. 22)



Подсоедините к этому разъему кабель с 4-контактным разъемом Molex, если в компьютере установлено более три видеокарт.

Разъем порта печати
 (25-выводов LPT1)
 (см. стр. 1, п. 20)

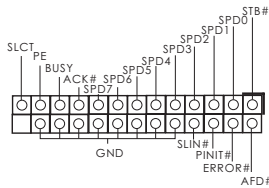

Это интерфейс кабеля порта печати, обеспечивающий удобное подключение принтеров.

Колodka TPM
 (17-контактная, TPMS1)
 (См. стр. 1, п. 19)

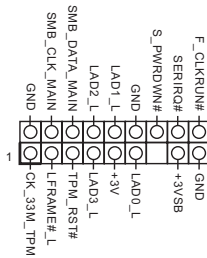

Этот разъем обеспечивает поддержку системы Trusted Platform Module (TPM), которая способна обеспечить надежное хранение ключей, цифровых сертификатов, паролей и данных. Система TPM также повышает уровень сетевой безопасности, защищает цифровые идентификаторы и обеспечивает целостность платформы.

1. Introdução

Gratos por comprar nossa placa-mãe **FM2A58M+ BTC** um produto confiável feito com ASRock um estrito controle de qualidade consistente. Com um excelente desempenho, essa placa é dotada de um projeto robusto que atende a ASRock de compromisso com a qualidade e durabilidade.

Este Guia de Instalação Rápida apresenta a placa-mãe e o guia de instalação passo a passo. Mais informações detalhadas sobre a placa-mãe podem ser encontradas no manual do usuário do CD de suporte.



Porque as especificações da placa mãe e o software de BIOS poderiam ser atualizados, o conteúdo deste manual pode ser cambiado sem aviso. Em caso de qualquer modificação deste manual, a versão atualizada estará disponível no website de ASRock sem prévio aviso. Pode também encontrar as listas das mais recentes placas VGA e das CPUs suportadas no site da web da ASRock.

Website de ASRock <http://www.asrock.com>

Se precisar de apoio técnico em relação a este placa-mãe, por favor visite o nosso sítio da internet para informação específica acerca do modelo que está a utilizar.

www.asrock.com/support/index.asp

1.1 Este pacote contém

Placa-mãe ASRock **FM2A58M+ BTC** (Formato ATX)

Guia de instalação rápida da ASRock **FM2A58M+ BTC**

CD de suporte da placa ASRock **FM2A58M+ BTC**

Dois cabo de dados ATA Serial (SATA) (Opcional)

Uma proteção I/O

1.2 Especificações

Plataforma	<ul style="list-style-type: none"> • Formato Micro ATX • Design de condensadores banhados a ouro de alta qualidade • PCB de Fibra de Vidro de Alta Densidade
CPU	<ul style="list-style-type: none"> • Suporte para processadores com Socket FM2 de 100W • Alimentação de 4 + 2 fases
Chipsets	<ul style="list-style-type: none"> • AMD A58 FCH (Bolton-D2)
Memória	<ul style="list-style-type: none"> • Suporte à tecnologia de memória de duplo canal • 2 x slots de DDR3 DIMM • Suporta memória DDR3 1866/1600/1333/1066, não ECC, sem tampão • Capacidade máxima de memória do sistema: 32GB • Suporta Extreme Memory Profile (XMP) 1.3/1.2 da Intel® • Suporta Tecnologia de Perfil de Memória AMD (AMP) • Contato em Ouro 15µ em Slots DIMM
Slots de Expansão	<ul style="list-style-type: none"> • 1 x slots de PCI Express 3.0 x16 (PCIe1: modo x16) * PCIe 3.0 é suportado apenas com CPU FM2+. CPU FM2 suporta apenas PCIe 2.0. • 3 x slots de PCI Express 2.0 x1 • Contato em Ouro 15µ no Slot VGA PCIe (PCIe1)
VGA integrado	<ul style="list-style-type: none"> • Placa gráfica integrada AMD Radeon™ série R7/R5 na APU série A • DirectX 11.1, Pixel Shader 5.0 com CPU FM2+. DirectX 11, Pixel Shader 5.0 com CPU FM2. • Memória partilhada máxima 2GB • Porta de saída VGA dupla: suporta portas DVI-D e D-Sub através de controladores de visualização independentes • Suporta Dual-link DVI-D com resolução máxima até 2560x1600 @ 60Hz

- Suporta D-Sub com resolução máxima até 1920x1200 @ 60Hz
- Suporta AMD Steady Video™ 2.0: Nova capacidade de pós-processamento de vídeo para redução automática de vibrações em vídeo local/online
- Suporta função HDCP com porta DVI-D
- Suporta a norma Blu-ray de alta definição 1080p (BD) / e a reprodução de DVDs de alta definição com porta DVI-D

Áudio

- Áudio HD de 5.1 canais (Realtek ALC662 Audio Codec)
- Suporta Proteção Contra Surto (Proteção Total contra Picos ASRock)
- TI® NE5532 (suporta amplificador de auscultadores premium até 600 Ohms) (Saída de Linha na I/O traseira apenas)

LAN

- PCIE x1 Gigabit LAN 10/100/1000 Mb/s
- Realtek RTL8111GR
- Suporta Wake-On-WAN
- Suporta Wake-On-LAN
- Suporta Proteção contra Relâmpago/ESD (Proteção Total contra Picos ASRock)
- Suporta Detecção de cabo LAN
- Suporta Ethernet com Eficiência Energética 802.3az
- Suporta PXE

Entrada/ Saída pelo painel

- 1 x porta para mouse PS/2
- 1 x porta para teclado PS/2
- 1 x porta D-Sub
- 1 x porta DVI-D
- 6 x portas USB 2.0 padrão (Suporta Proteção ESD (Proteção Total contra Picos ASRock))
- 1 x porta LAN RJ-45 com LED (LED ACT/LIG e LED VELOCIDADE)
- Ficha de áudio HD: Entrada de linha / Altifalante frontal Microfone

- Armazenamento**
- 6 x conectores SATA2 a 3,0 Gb/s, com suporte para RAID (RAID 0, RAID 1 e RAID 10), NCQ, AHCI e funções Hot Plug

- Conectores**
- 1 x Conector de Porta de Impressão
 - 1 x Terminal TPM
 - 2 x Conector do ventilador da CPU (1 x 4 pinos, 1 x 3 pinos)
 - 2 x Conector do ventilador da chassis (1 x 4 pinos, 1 x 3 pinos)
 - 1 x Conector do ventilador da energia (3 pinos)
 - 1 x Conector de força do ATX de 24 pinos
 - 1 x Conector ATX 12 V de 8 pinos
 - 1 x conector de alimentação PCIe
 - 1 x Conector Áudio do painel frontal
 - 1 x jumper de alimentação USB (Energia Ultra USB)
 - 2 x cabezal USB 2.0 (suporta 4 portas USB 2.0) (Suporta Proteção ESD (Proteção Total contra Picos ASRock))

- BIOS**
- 64Mb BIOS UEFI oficial da AMI com suporte para GUI
 - Suporta dispositivos "Plug and Play"
 - ACPI 1.1 atendendo a eventos de "wake up"
 - Suporta dispositivos sem jumper
 - Suporte para SMBIOS 2.3.1
 - DRAM, CPU, SB Voltage Multi-adjustment

- CD de suporte**
- Controladores, utilitários, software antivírus (Experimentacao Versao), Navegador Google Chrome e Barra de Ferramentas, Start8 (30 dias de avaliação)

- Monitor do HW**
- Sensores de temperatura do procesador
 - Medição de temperatura da placa-mãe
 - Tacômetros de ventilador do Processador
 - Tacômetros de ventilador do chassis
 - Ventoinha silenciosa para a CPU/Chassis

- CPU/Chassis Fan Controle Multi-Velocidade
- Monitoramento de voltagem : +12 V, +5 V, +3.3 V, Vcore

Sistema Operacional

- Microsoft® Windows® 8.1 de 32 bits / 8.1 de 64 bits / 8 de 32 bits / 8 de 64 bits / 7 de 32 bits / 7 de 64 bits / XP de 32 bits / XP de 64 bits

Certificações

- FCC, CE, WHQL
- “ErP/EuP Ready” (é necessária alimentação eléctrica “ErP/ EuP Ready”)

* Para informações mais detalhadas por favor visite o nosso sítio Web:
<http://www.asrock.com>

1.3 Configuração dos Jumpers

A ilustração mostra como os jumpers são configurados. Quando há uma capa de jumpers sobre os pinos, diz-se que o jumper está “curto”. Não havendo capa sobre os pinos, o jumper está “aberto”. A ilustração mostra um jumper de 3 pinos em que os pinos 1 e 2 estão “curtos” quando a capa de jumper estiver colocada sobre esses 2 pinos.

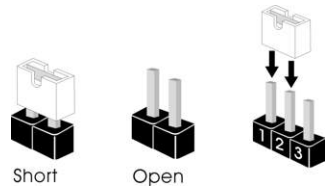

Jumper	Configuração
Restaurar CMOS	<div style="display: flex; justify-content: space-around; align-items: center;"> <div style="text-align: center;"> <p>1_2</p> <p>Configuração-padrão</p> </div> <div style="text-align: center;"> <p>2_3</p> <p>Limpar o CMOS</p> </div> </div>
Jumper de Alimentação USB	<div style="display: flex; justify-content: space-around; align-items: center;"> <div style="text-align: center;"> <p>1_2</p> <p>+5V (Padrão)</p> </div> <div style="text-align: center;"> <p>2_3</p> <p>+5VSB</p> </div> </div>

Restaurar CMOS

(CLRCMOS1, jumper de 3 pinos)

(veja a folha 1, No. 8)



Nota: CLRCMOS1 permite você limpar os dados em CMOS. Os dados em CMOS incluem informações da configuração do sistema como: por exemplo a senha do sistema, data, tempo, e os parâmetros da configuração do sistema. Para limpar e reconfigurar os parâmetros do sistema a configuração inicial da fábrica, por favor desligue o cabo de força, ponha em curto-circuito os pin 2 e pin 3 de CLRCMOS1 por mais de 5 segundos para limpar o CMOS usando um jumper. Por favor lembre-se de remover o jumper depois de limpar o CMOS. Se precisar limpar o CMOS ao concluir a atualização do BIOS, deverá reiniciar o sistema primeiro e, em seguida, desligá-lo antes de executar a ação de limpeza o CMOS. Tenha em atenção que a palavra-passe, data, hora, perfil predefinido de utilizador, 1394 GUID e endereço MAC apenas serão limpos se a bateria do CMOS for retirada.

Jumper de Alimentação

USB

(3-pinos USB01_PWR1)

(veja a folha 1, No. 24)



Nota:

O Jumper de Alimentação USB é projetado especificamente para os usuários que utilizam teclado / mouse de LED. (apenas para a porta USB01)

Pino 1-2 mais curto (padrão):

Tensão estável e alta corrente são fornecidas para teclado / mouse de LED.

A luz de fundo do teclado / mouse será DESLIGADA quando o PC é desligado.

Pino 2-3 mais curto:

Tensão de +5VSB é fornecida para teclado / mouse de LED.

Habilitar a função de despertar do seu teclado / mouse.

A luz de fundo do teclado / mouse será LIGADA quando o PC está em modo de espera.

1.4 Conectores



Os conectores NÃO SÃO jumpers. NÃO coloque capas de jumper sobre estes conectores. A colocação de pontos de jumper sobre os conectores causará danos irreversíveis à placa-mãe.

Conectores ATA2 Serial

(SATA_1: veja a folha 1, No. 15)

(SATA_2: veja a folha 1, No. 16)

(SATA_3: veja a folha 1, No. 14)

(SATA_4: veja a folha 1, No. 13)

(SATA_5: veja a folha 1, No. 12)

(SATA_6: veja a folha 1, No. 11)

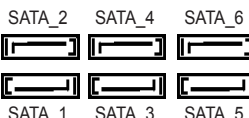

Estes seis conectores Serial

ATA (SATA2) suportam

unidades de disco rígido SATA

ou SATA2 como dispositivos de

armazenamento internos. A

atual interface SATA2 permite

uma taxa de transferência de

dados de até 3.0 Gb/s.

Cabezal USB 2.0

(USB45 de 9 pinos)

(veja a folha 1, No. 17)

(USB67 de 9 pinos)

(veja a folha 1, No. 18)

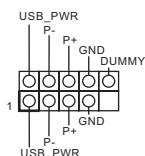

Além das seis portas USB 2.0

por defeito no painel de

entrada/saída, há dois ligações

USB 2.0 nesta placa-mãe.

Cada ligação USB 2.0 pode

suportar duas portas USB 2.0.

Conector Áudio do painel frontal

(HD_AUDIO1 de 9 pinos)

(veja a folha 1, No. 21)

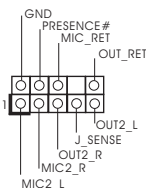

Esta é uma interface para o

cabo de áudio no painel frontal,

que permite uma conexão e

controle convenientes dos

dispositivos de áudio.



1. Áudio de elevada definição que suporta a sensibilidade da tomada, mas o fio do painel existente no chassis tem de suportar HDA para funcionar correctamente. Siga as instruções que aparecem no manual e no manual do chassis para instalar o sistema.
2. Se utilizar o painel de áudio AC'97, instale-o no cabeçalho de áudio do painel frontal, como a figura abaixo mostra:
 - A. Ligue o Mic_IN (MIC) ao MIC2_L.
 - B. Ligue o Audio_R (RIN) ao OUT2_R e o Audio_L (LIN) ao OUT2_L.
 - C. Ligue o Ground (GND) ao Ground (GND).
 - D. MIC_RET e OUT_RET são apenas para o painel de áudio HD. Não necessita de os ligar para o painel de áudio AC'97.

E. Para activar o microfone frontal.

Para os Sistemas Operativos Windows® 8.1 / 8.1 64-bit / 8 64-bit / 7 / 7 64-bit / XP / XP 64-bit:

Aceda ao separador "Microfone frontal" no painel de Controlo Realtek. Ajuste o "Volume de gravação".

Conector do painel do sistema

(PANEL1 de 9 pinos)

(veja a folha 1, No. 10)

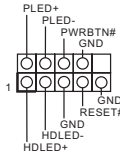

Este conector acomoda várias funções do painel frontal do sistema.



Ligue o botão de alimentação, o botão de reposição e o indicador do estado do sistema no chassis a este conector de acordo com a descrição abaixo. Tenha em atenção os pinos positivos e negativos antes de ligar os cabos.

PWRBTN (Botão de alimentação):

Ligue ao botão de alimentação no painel frontal do chassis. Pode configurar a forma para desligar o seu sistema através do botão de alimentação.

RESET (Botão de reposição):

Ligue ao botão de reposição no painel frontal do chassis. Prima o botão de reposição para reiniciar o computador caso este bloqueie e não seja possível reiniciar normalmente.

PLED (LED de alimentação do sistema):

Ligue ao indicador do estado da alimentação no painel frontal do chassis. O LED ficará acesso quando o sistema estiver em funcionamento. O LED ficará intermitente quando o sistema estiver no estado de suspensão S1. O LED ficará desligado quando o sistema estiver nos estados de suspensão S3/S4 ou desligado (S5).

HDLED (LED de actividade do disco rígido):

Ligue ao LED de actividade do disco rígido no painel frontal do chassis. O LED ficará acesso quando o disco rígido estiver a ler ou a escrever dados.

O design do painel frontal poderá variar dependendo do chassis. Um módulo de painel frontal consiste principalmente em um botão de alimentação, um botão de reposição, um LED de alimentação, um LED de actividade do disco rígido, um altifalante, etc. Ao ligar o seu módulo de painel frontal do chassis a este conector, certifique-se que os fios e os pinos têm uma correspondência exacta.

Conector do alto-falante do chassi

(SPEAKER1 de 4 pinos)
(veja a folha 1, No. 9)

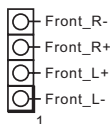

Ligue o alto-falante do chassi neste conector.

Conector do ventilador do chassis/energia

(CHA_FAN1 de 4 pinos)
(veja a folha 1, No. 7)

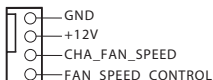

Ligue o cabo do ventilador neste conector, coincidindo o fio preto com o pino de aterramento.

(CHA_FAN2 de 3 pinos)
(veja a folha 1, No. 23)

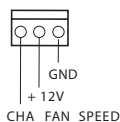

(PWR_FAN1 de 3 pinos)
(veja a folha 1, No. 2)

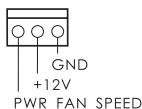

Conector do ventilador da CPU

(CPU_FAN1 de 4 pinos)
(veja a folha 1, No. 3)

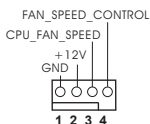

Ligue o cabo do ventilador da CPU, coincidindo o fio preto com o pino de aterramento.



Apesar de esta placa-mãe possuir 4 apoios para uma ventoinha de CPU (Ventoinha silenciosa), uma ventoinha de 3 pinos para CPU poderá funcionar mesmo sem a função de controlo de velocidade da ventoinha. Se pretender ligar uma ventoinha de 3 pinos para CPU ao conector de ventoinha do CPU nesta placa-mãe, por favor, ligue-a aos pinos 1-3.

Pinos 1-3 ligados ←

Instalação de Ventoinha de 3 pinos



(CPU_FAN2 de 3 pinos)
(veja a folha 1, No. 4)

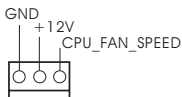

Conector de força do ATX

(ATXPWR1 de 24 pinos)

(veja a folha 1, No. 6)

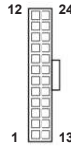

Ligue a fonte de alimentação ATX neste conector.



Embora esta placa-mãe providencie um conector de energia ATX de 24 pinos, pode apesar disso funcionar com a adaptação de uma fonte de energia tradicional de 20 pinos. Para usar a fonte de alimentação de 20 pinos, por favor ligue a sua fonte de alimentação com o Pino 1 e o Pino 13.



Instalação da Fonte de alimentação ATX de 20 Pinos

Conector de força do ATX 12V

(ATX12V1 de 8 pinos)

(veja a folha 1, No. 1)

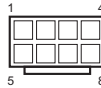

Ligue a fonte de alimentação ATX 12V neste conector.



Embora esta placa-mãe providencie um conector de energia ATX 12V de 8 pinos, pode apesar disso funcionar com a adaptação de uma fonte de energia tradicional de 4 pinos. Para usar a fonte de alimentação de 4 pinos, por favor ligue a sua fonte de alimentação com o Pino 1 e o Pino 5.

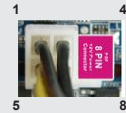

Instalação da Fonte de alimentação ATX 12V de 4 Pinos

Conector de alimentação PCIe

(4-pinos PCIE_PWR1)

(see p.10, No. 22)



Por favor conecte um cabo de alimentação molex de 4 pinos a este conector quando mais de três placas de vídeo estão instaladas.

Porta de impressão

(LPT1 de 25 pinos)

(consultar p.1, No. 20)

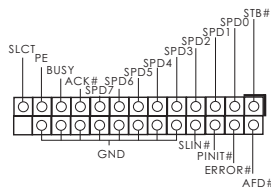

Esta é a interface do cabo que liga à porta de impressão e permite a fácil ligação de impressoras.

Terminal TPM
 (TPMS1 de 17 pinos)
 (consultar p.1, No. 19)

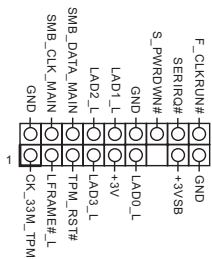

Este conector suporta um sistema com Módulo de Plataforma Confiável (TPM), que pode armazenar com segurança chaves, certificados digitais, palavras-passe e dados. Um sistema TPM também ajuda a melhorar a segurança de rede, a proteger identidades digitais e a garantir a integridade da plataforma.

1. Giriş

ASRock'ın kesintisiz titiz kalite denetimi altında üretilen güvenilir bir anakart olan ASRock **FM2A58M+ BTC** anakartını satın aldığınız için teşekkür ederiz. ASRock'ın kalite ve dayanıklılık konusundaki kararlılığına uygun güçlü tasarımıyla mükemmel bir performans sunar.

Bu Hızlı Takma Kılavuzu anakarta giriş ve adım adım takma kılavuzu içerir. Anakart hakkında daha ayrıntılı bilgiyi Destek CD'sinde sunulan kullanıcı kılavuzunda bulabilirsiniz.



Anakart özellikleri ve BIOS yazılımı güncelleştirilebileceğinden bu kılavuzun içeriği önceden haber verilmeksizin değişebilir. Bu belgede değişiklik yapılması durumunda, güncelleştirilmiş sürüm ayrıca haber verilmeksizin ASRock web sitesinde sunulur. En son VGA kartlarını ve CPU destek listelerini de ASRock web sitesinde bulabilirsiniz. ASRock web sitesi <http://www.asrock.com>

Bu anakartla ilgili teknik desteğe ihtiyacınız olursa, kullandığınız modele özel bilgiler için lütfen web sitemizi ziyaret edin.
www.asrock.com/support/index.asp

1.1 Paket İçindekiler

- ASRock **FM2A58M+ BTC** Anakart (ATX Form Faktörü)
- ASRock **FM2A58M+ BTC** Hızlı Takma Kılavuzu
- ASRock **FM2A58M+ BTC** Destek CD'si
- 2 x Seri ATA (SATA) Veri Kablosu (İsteğe Bağlı)
- 1 x G/Ç Panel Kalkanı

1.2 Özellikler

Platform

- Micro ATX Form Faktörü
- Tüm Katı Kapasitör tasarımı
- Yüksek Yoğunluklu Cam Elyafı Kumaş PCB

CPU

- Yuva FM2+ 95W / FM2 100W işlemciler için destek
- 4 + 2 Güç Fazı Tasarımı

Yonga seti

- AMD A58 FCH (Bolton-D2)

Bellek

- Çift Kanallı DDR3 Belleği Teknolojisi
- 2 x DDR3 DIMM yuva
- DDR3 1866/1600/1333/1066 ECC olmayan, ara belleksiz bellek
- Sistem belleğinin maks. kapasitesi: 32 GB
- Intel® Extreme Bellek Profi lini (XMP)1.3/1.2 destekler
- AMD Bellek Profi lini (AMP) destekler
- DIMM Yuvalarında 15µ Altın Temas Noktası

Genişletme Yuvası

- 1 x PCI Express 3.0 x16 yuva (PCIe1: x16 modu)
* PCIe 3.0 yalnızca FM2+ İşlemci ile desteklenir.
FM2 İşlemciyle, yalnızca PCIe 2.0 destekler.
- 3 x PCI Express 2.0 x1 yuva
- Dalgalanma Korumasını destekler (ASRock Tam Ani Yükseliş Koruması) (PCIe1)

Grafikler

- A serisi APU'da tümleşik AMD Radeon™ R7/R5 serisi grafikler
- FM2+ İşlemciyle DirectX 11.1, Pixel Shader 5.0. FM2 İşlemciyle DirectX 11, Pixel Shader 5.0.
- Maks. paylaşılan bellek 2GB
- Çift VGA Çıkış: desteği DVI-D ve bağımsız görüntü denetleyiciler tarafından D-Sub bağlantı noktaları
- 60Hz'de 2560x1600'e kadar maks. çözünürlükle Dual-link DVI-D'ye destekler
- 60Hz'de 1920x1600'ya kadar maks. çözünürlükle D-Sub'e destekler

- AMD Steady Video™ 2.0'yu destekler: Ev/çevrimiçi videoda otomatik titreşim azaltma için yeni video işleme sonrası özelliği
- DVI-D portlarıyla HDCP işlevini destekler
- DVI-D portlarıyla Tam HD 1080p Blu-ray (BD) / HD-DVD oynatımına destekler

Ses

- (Realtek ALC662 Ses Codec'i) 5,1 Kanal HD Ses
- Dalgalanma Korumasını destekler (ASRock Tam Ani Yükseliş Koruması)
- TI® NE5532 (600 Ohm'a kadar Premium Kulaklık Yükselticisi desteği) (Yalnızca arka G/Ç üzerinde Hat Çıkışı)

LAN

- PCIE x1 Gigabit LAN 10/100/1000 Mb/sn
- Realtek RTL8111GR
- WAN üzerinden açma destekler
- LAN'da Uyan özelliğini destekler
- Yıldırım/ESD Korumasını destekler (ASRock Tam Ani Yükseliş Koruması)
- LAN Kablo Algılama'yı destekler
- Enerji Verimli Ethernet 802.3az desteği
- PXE'yi destekler

Arka Panel G/3

- 1 x PS/2 Fare Portu
- 1 x PS/2 Klavye Portu
- 1 x D-Sub Portu
- 1 x DVI-D Portu
- 6 x Kullanıma Hazır USB 2.0 Portu (ESD Korumasını destekler (ASRock Tam Ani Yükseliş Koruması))
- 1 x RJ-45 LAN Portu, LED'li (AKT/LƏNK LED'i ve HIZ LED)
- HD Ses Jaki: Hat Girişi / Ön Hoparlör / Mikrofon

Depolama

- 6 x SATA2 3,0Gb/sn konektör, donanım RAID (RAID 0, RAID 1 ve RAID 10), NCQ, AHCI ve "Sistem Azakken Bileşen Takma" işlevlerini

Konektör

- 1 x Yazdırma Portu fişi
- 1 x TPM bağlantısı
- 2 x CPU FAN konektörü (1 x 4 pin, 1 x 3 pin)
- 2 x Kasa FAN konektörü (1 x 4 pin, 1 x 3 pin)
- 1 x Gb3 FAN konektörü (3 pin)
- 1 x 24 pin ATX güç konektörü
- 1 x 8 pin 12V güç konektörü
- 1 x PCIe Güç Konektörü
- 1 x Ön panel ses konektörü
- 1 x USB Güç Atlatici (Üstün USB Gücü)
- 2 x USB 2.0 fişi (4 USB 2.0 portu destekler) (ESD Korumasını destekler (ASRock Tam Ani Yükseliş Koruması))

**BIOS
Özelliği**

- Çok dilli GUI desteğiyle 64Mb AMI UEFI Legal BIOS
- "Tak Çalıştır"ı destekler
- ACPI 1.1 Uyumlu Uyandırma Olayları
- Jumpersız ayarlamayı destekler
- AMBIOS 2.3.1 Desteği
- DRAM, CPU, SB Voltaj Çoklu ayarı

**Destek
CD'si**

- Sürücüler, Yardımcı Programlar, AntiVirüs Yazılımı (Deneme Sürümü), Google Chrome Browser ve Toolbar, Start8 (30 günlük deneme)

**Donanım
Monitör**

- CPU Sıcaklık Duyarlılığı
- Kasa Sıcaklık Duyarlılığı
- CPU Fan Takometresi
- Kasa Fan Takometresi
- CPU/Kasa Sessiz Fanı
- CPU/Kasa Fan Çoklu-Hız Kontrolü
- Voltaj İzleme: +12V, +5V, +3,3V, CPU Vcore

İS

- Microsoft® Windows® 8.1 32-bit / 8.1 64-bit / 8 32-bit / 8 64-bit / 7 32-bit / 7 64-bit / XP 32-bit / XP 64-bit

**Sertifika-
lar**

- FCC, CE, WHQL
- ErP/EuP Hazır (ErP/EuP hazır güç kaynağı gerekli)

* Ayrıntılı ürün bilgileri için lütfen web sitemizi ziyaret edin: <http://www.asrock.com>

1.3 Jumper'ların Ayarı

Şekilde jumper'ların nasıl ayarlandıkları gösterilmektedir. Jumper kapağı pinler üzerine yerleştirildiğinde jumper "Kapalı" dır. Jumper kapağı pinler üzerindeyken jumper "Açık" tır. Şekilde pin1 ve pin2'si "Kapalı" olan jumper kapağı bu 2 pine yerleştirilmiş 3-pinli jumper gösterilmektedir.

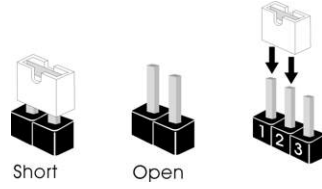

Jumper

Ayar

CMOS'u temizleme

(CLRCMOS1, 3-pinli jumper)

(bkz. s.1 No. 8)



Default



Clear CMOS

Not: CLRCMOS1, CMOS'daki verilerinizi temizlemenize olanak sağlar. Sistem parametrelerini temizlemek ve varsayılan ayara sıfırlamak için lütfen bilgisayarı kapatın ve güç kablosunun fişini güç kaynağından çekin. 15 saniye bekledikten sonra, pin2 ve pin3'ü CLRCMOS1'de 5 saniye kısaltmak için bir atlatıcı şapkası kullanın. Ancak, BIOS'u güncelledikten hemen sonra lütfen CMOS'u temizlemeyin. BIOS'u güncellemeyi tamamladığınızda CMOS'u temizlemeniz gerekirse, ilk olarak sistemi başlatmanız ve ardından CMOS temizleme işlemini gerçekleştirmeden önce kapatmanız gereklidir. Parola, tarih, saat, kullanıcı varsayılan profili, 1394 GUID ve MAC adresinin yalnızca CMOS pili çıkarıldığında temizleneceğini lütfen aklınızda bulundurunuz.

USB Güç Atlatıcı

(3 pimli USB01_PWR1)

(bkz. s.1 No. 24)



+5V (Varsayılan)



+5VSB

Not: USB Güç Atlatıcı, LED klavye/fare kullanan kullanıcılar için özel olarak tasarlanmıştır. (sadece USB01 portu için)

Pim 1-2 kısa devre (varsayılan):

Kararlı gerilim ve yüksek akım LED klavye/fare için sağlar.

Bilgisayar kapalıyken, klavyenizin/farenizin arka ışığı KAPALI olacaktır.

Pim 2-3 kısa devre:

+5VSB gerilim LED klavye/fare için sağlar.

Klavyenizin/Farenizin uyanma işlevini etkinleştirin.

Bilgisayar bekleme modundayken, klavyenizin/farenizin arka ışığı AÇIK olacaktır.

1.4 Yerleşik Fişler ve Konektörler



Yerleşik fişler ve konektörler jumper DEĞİLDİR. Bu fişlerin ve konektörlerin üzerine jumper kapakları YERLEŞTİRMEYİN. Fişlerin ve konektörlerin üzerine jumper kapakları yerleştirmek anakartın kalıcı olarak zarar görmesine neden olabilir!

Seri ATA2 Konektörler

(SATA_1: bkz. s.1, No. 15)

(SATA_2: bkz. s.1, No. 16)

(SATA_3: bkz. s.1, No. 14)

(SATA_4: bkz. s.1, No. 13)

(SATA_5: bkz. s.1, No. 12)

(SATA_6: bkz. s.1, No. 11)



Bu sekiz Seri ATA2 (SATA2) konektör, dahili depolama cihazları için SATA veri kablolarını destekler. Geçerli SATA2 arayüzü 3,0 Gb/sn veri aktarım hızına izin verir.

USB 2.0 Fişleri

(9-pinli USB45)

(bkz. s.1 No. 17)

(9-pinli USB67)

(bkz. s.1 No. 18)

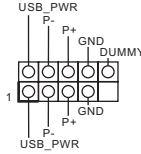

G/Ç panelindeki varsayılan dört USB 2.0 portundan başka, bu anakartta iki USB 2.0 fişi bulunur. Her USB 2.0 fişi iki USB 2.0 portunu destekler.

Ön Panel Ses Fişi

(9-pinli HD_SES1)

(bkz. s.1 No. 21)

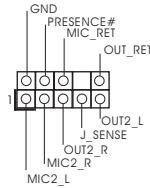

Bu, panel ses kablosu için uygun bağlantı sağlayan ve ses cihazlarını kontrol etmeyi sağlayan bir arayüzdür.



1. Yüksek Tanımlı Ses Jak Duyarlılığını destekler, ancak kasadaki panel kablosunun HDA'nın düzgün çalışmasını desteklemesi gerekir. Lütfen sisteminizi yüklemek için kılavuzumuzdaki ve kasa kılavuzundaki talimatları izleyin.
2. AC'97 ses paneli kullanıyorsanız, lütfen ön panel ses fişine aşağıdaki gibi takın:
 - A. Mic_IN'i (MIC) MIC2_L'ye bağlayın.
 - B. Audio_R'yi (RIN) OUT2_R'ye ve Audio_L'yi (LIN) OUT2_L'ye bağlayın.
 - C. Ground'u (GND) Ground'a (GND) bağlayın.
 - D. MIC_RET ve OUT_RET yalnızca HD ses paneli içindir. Bunları AC'97 ses paneli için bağlamanız gerekmez.

E. Ön mikrofonu etkinleştirmek için

Windows® 8.1 / 8.1 64-bit / 8 / 8 64-bit / 7 / 7 64-bit / XP / XP 64-bit İS için:
Realtek Kontrol panelinde "Ön Mikrofon" Sekmesine gidin. "Kayıt Ses Seviyesi"ni ayarlayın.

Sistem Paneli Fişi

(9-pinli PANEL1)

(bkz. s.1 No. 10)

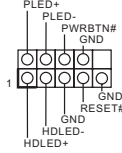

Bu fiş, birçok sistem ön paneli işlevini barındırır.



Kasa üzerindeki güç anahtarını, sıfırlama anahtarını ve sistem durumu göstergesini aşağıdaki pin atamalarına göre bu bağlantıya bağlayın. Kabloları bağlamadan önce pozitif ve negatif pinlere dikkat edin.

PWRBTN (Güç Anahtarı):

Kasa üzerindeki güç anahtarını ön panele bağlayın. Güç anahtarını kullanarak sisteminizi kapatma şeklinizi yapılandırabilirsiniz.

RESET (Sıfırlama Anahtarı):

Kasa üzerindeki sıfırlama anahtarını ön panele bağlayın. Bilgisayar donarsa veya normal bir yeniden başlatma gerçekleştirilemezse, bilgisayar yeniden başlatmak için sıfırlama anahtarına basın.

PLED (Sistem Gücü LED'i):

Kasa üzerindeki güç durumu göstergesini ön panele bağlayın. Sistem çalışırken LED yanar. Sistem S1 uyku modunda iken LED yanıp sönmeye devam eder. Sistem S3/S4 uyku modunda veya kapalı (S5) iken LED söner.

HDLED (Sabit Disk Çalışma LED'i):

Kasa üzerindeki sabit disk çalışma LED'ini ön panele bağlayın. Sabit disk veri okurken veya yazarken LED yanar.

Ön panel tasarımı kasaya göre değişiklik gösterebilir. Ön panel modülünde temel olarak güç anahtarı, sıfırlama anahtarı, güç LED'i, sabit disk çalışma LED'i, hoparlör vb. bulunur. Kasa ön panel modülünüzü bu bağlantıya bağlarken, kablo atamalarının ve pin atamalarının doğru biçimde eşleştirildiğinden emin olun.

Kasa Hoparlörü Fişi

(4-pinli SPEAKER1)

(bkz. s.1 No. 9)

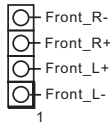

Lütfen kasa hoparlörünün bu fişe bağlayın.

Kasa/güç Fan Konektörü

(4-pinli CHA_FAN1)

(bkz. S.1 No. 7)

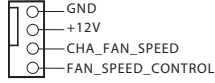

Lütfen kasa fan kablolarını fanına bu konektöre bağlayın ve siyah kabloyu toprak pinine bağlayın.

(3-pinli CHA_FAN2)

(bkz. S.1 No. 23)

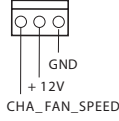

(3-pinli PWR_FAN1)

(bkz. S.1 No. 2)

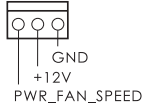
**CPU Fan Konektörü**

(4-pinli CPU_FAN1)

(bkz. S.1 No. 3)

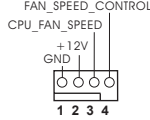

Lütfen fan kablolarını CPU fanına bu konektöre bağlayın ve siyah kabloyu toprak pinine bağlayın.



Bu anakart 4-Pinli CPU fan (Sessiz Fan) desteği sağlasa da, 3-Pinli CPU fan hızı kontrol işlevi olmadan bile hala başarılı bir şekilde çalışabilir. 3-Pinli CPU fanı bu konektördeki CPU fan konektörüne bağlamayı planlıyorsanız, lütfen Pin 1-3'e bağlayın.

Pin 1-3 Bağlı ←

3-Pinli Fanı Takma



(3-pinli CPU_FAN2)

(bkz. S.1 No. 4)

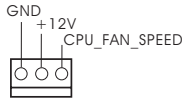
**ATX Güç Konektörü**

(24-pinli ATXPWR1)

(bkz. S.1 No. 6)

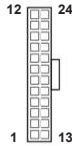

Lütfen bir ATX güç kaynağını bu konektöre bağlayın.



Bu anakart 24-pinli ATX güç konektörü sağlasa da geleneksel bir 20-pinli ATX güç kaynağı bağlarsanız da çalışabilir. 20-pinli ATX güç kaynağını kullanmak için, lütfen güç kaynağını Pin 1 ve Pin 13'le birlikte takın.



20-Pinli ATX Güç Kaynağını Takma

ATX 12V Güç Konektörü

(8-pinli ATX12V1)

(bkz. S.1 No. 1)

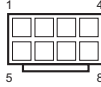

Lütfen bir ATX 12V güç kaynağını bu konektöre bağlayın.



Bu anakart 8-pinli ATX 12V güç konektörü sağlasa da geleneksel bir 4-pinli ATX 12V güç kaynağı bağlarsanız da çalışabilir. 4-pinli ATX güç kaynağını kullanmak için, lütfen güç kaynağını Pin 1 ve Pin 5'le birlikte takın.

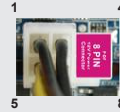

4-Pinli ATX 12V Güç Kaynağını Takma

PCIe Güç Konektörü

(4 pimli PCIe_PWR1)

(see p.1, No. 22)



Üçden fazla ekran kartı takıldığında, lütfen bu konektöre 4 pimli molex güç kablosu bağlayın.

Yazdırma Portu Fişi

(25-pinli LPT1)

(bkz. s.1 No. 20)

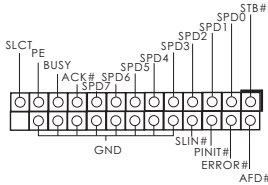

Bu, yazdırma portu kablosu için yazıcı cihazlarının uygun bağlanmasını sağlayan bir arayüzdür.

TPM Bağlantısı
(17-pin TPMS1)
(bkz. sf.1, No. 19)

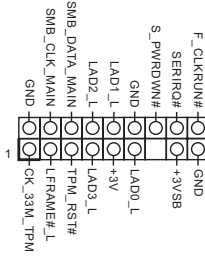

Bu bağlayıcı, anahtarlar, dijital sertifikalar, parolalar ve verileri güvenli bir şekilde saklama özelliği bulunan Güvenilir Platform Modülü (TPM) sistemini destekler. TPM sistemleri, aynı zamanda ağ güvenliğinin artırılması, dijital kimliklerin korunması ve platform bütünlüğünün sağlanmasına da yardımcıdır.

1. 제품소개

ASRock의 **FM2A58M+ BTC** 메인 보드를 구매하여 주신것에 대하여 감사 드립니다. 이 메인보드는 엄격한 품질관리 하에 생산되어진 신뢰성 있는 메인보드입니다. 이 제품은 고 품격 디자인과 함께 ASRock의 우수한 품질과 최고의 안정성을 자랑하고 있습니다. 이 빠른 설치 안내서에는 마더보드에 대한 설명과 단계별 설치 방법이 실려 있습니다. 마더보드에 대한 보다 자세한 내용은 지원 CD의 사용 설명서에서 확인할 수 있습니다.



메인보드의 사양이나 바이오스가 업데이트 되기 때문에 이 사용자 설명서의 내용은 예고 없이 변경되거나 바뀔 수가 있습니다. 만일을 생각해서 이 사용자 설명서의 어떤 변경이 있으면 ASRock의 웹사이트에서 언제든지 업데이트를 하실 수 있습니다. 웹사이트에서 최신 VGA 카드와 CPU 지원 목록을 확인할 수 있습니다. ASRock의 웹사이트 주소는 <http://www.asrock.com>입니다. 본 마더보드와 관련하여 기술 지원이 필요한 경우 당사 웹사이트를 방문하여 사용 중인 모델에 대한 특정 정보를 얻으십시오. www.asrock.com/support/index.asp

1.1 패키지 내용

- ASRock **FM2A58M+ BTC** 마더보드 (ATX 폼 팩터)
- ASRock **FM2A58M+ BTC** 쿼 설치 가이드
- ASRock **FM2A58M+ BTC** 지원 CD
- 시리얼 ATA (SATA) 데이터 케이블 2 개 (선택 사항)
- I/O 차폐 1 개

1.2 설명서

플랫폼	<ul style="list-style-type: none"> • Micro ATX 폼 팩터 • 완전 고체 축전지 디자인 • 고 밀도 유리 직물 PCB
CPU	<ul style="list-style-type: none"> • 소켓 FM2+ 95W / FM2 100W 프로세서에 대한 지원 • 4 + 2 전원 위상 디자인
칩셋	<ul style="list-style-type: none"> • AMD A58 FCH (Bolton-D2)
메모리	<ul style="list-style-type: none"> • 듀얼 채널 메모리 기술 지원 • DDR3 DIMM 슬롯 4 개 • DDR3 1866/1600/1333/1066 비 -ECC, 언버퍼드 메모리를 지원 • 최대 시스템 메모리 용량 : 32GB • Intel® 익스트림 메모리 프로파일 (XMP) 1.3/1.2 지원 • AMD 메모리 프로파일 (AMP) 지원 • DIMM 슬롯의 15 μ 금 접촉면
확장 슬롯	<ul style="list-style-type: none"> • 1 x PCI Express 3.0 x16 슬롯 (PCIe1: x16 모드) * PCIe 3.0 은 FM2+ CPU 에서만 지원됩니다 . FM2 CPU 의 경우 PCIe 2.0 만 지원합니다 . • 3 개의 PCI Express 2.0 x1 슬롯 • VGA PCIe 슬롯 (PCIe1) 의 15μ 금 접촉면
온보드 VGA	<ul style="list-style-type: none"> • A 시리즈 APU 에 통합된 AMD Radeon™ R7/R5 시리즈 그래픽 • FM2+ CPU 의 경우 DirectX 11.1, Pixel Shader 5.0 탑재 . FM2 CPU 의 경우 DirectX 11, Pixel Shader 5.0 탑재 . • 최대 공유 메모리 2GB • 더블 VGA 수출 : DVI-D 와 D-Sub 포트 독립 디스플레이 컨트롤러를 지원 • 최대 해상도 2560x1600 @ 60Hz 까지 Dual-link DVI-D 지원 • 최대 해상도 1920x1200 @ 60Hz 까지 D-Sub 지원 • AMD Steady Video™ 2.0 지원 : 홈 / 온라인 비디오의 자동 떨림감소를 위한 새로운 비디오 포스트 프로세싱 능력 • DVI 포트를 이용한 HDCP 기능 지원 • DVI 포트를 이용한 1080p Blu-ray (BD) / HD-DVD 재생을 지원

오디오

- 5.1 CH HD Audio (Realtek ALC662 Audio Codec)
- 서지 보호 (ASRock 풀 스파이크 보호) 지원
- TI® NE5532 (최대 600 옴의 프리미엄 헤드셋 증폭기 지원)

랜

- PCIE x1 Gigabit LAN 10/100/1000 Mb/s
- Realtek RTL8111GR
- Wake-On-WAN 지원
- 웨이크 - 온 - 랜 지원
- 조영 /ESD 보호 (ASRock 풀 스파이크 보호) 지원
- LAN 케이블 감지 지원
- 절전형 이더넷 802.3az 지원
- PXE 지원

후면판 I/O

- 1 개 PS/2 마우스 포트
- 1 개 PS/2 키보드 포트
- 1 개의 D-Sub 포트
- 1 개의 DVI-D 포트
- 6 개디폴트 USB 2.0 포트 (ESD 보호 (ASRock 풀 스파이크 보호) 지원)
- 1 개 LED(ACT/LINK LED 및 SPEED LED) 가 있는 RJ-45 LAN 포트
- 오디오 잭 : 라인 인 / 전방 스피커 / 마이크

저장 장치

- 6 개 의 SATA2 3.0Gb/s 커넥터 , RAID (RAID 0, RAID 1 및 RAID 10), NCQ, AHCI 및 “ 핫 플러그 ” 기능 지원

온보드 헤더
및 커넥터

- 프린트 포트 헤더 1 개
- TPM 헤더 1 개
- CPU 팬 커넥터 2 개 (4 핀 1 개 , 3 핀 1 개)
- 새시 팬 커넥터 2 개 (4 핀 1 개 , 3 핀 1 개)
- 전원 팬 커넥터 1 개 (3 핀)
- 24 핀 ATX 전원 헤더 1 개
- 8 핀 ATX 12V 파워 콘넥터 1 개
- PCIe 전원 커넥터 1 개
- 전면부 오디오 콘넥터 1 개
- USB 전원 점프 1 개 (울트라 USB 전원)
- USB 2.0 헤더 2 개 (4 개의 추가 USB 2.0 포트를 지원하는 헤더 2 개) (ESD 보호 (ASRock 풀 스파이크 보호) 지원)

BIOS

- 64Mb GUI 지원을 제공하는 AMI UEFI 적합형 BIOS
- “플러그 앤 플레이”지원
- ACPI 1.1 웨이크 - 업 이벤트와의 호환
- 점퍼 프리 지원

- 점퍼 프리 지원 ; SMBIOS 2.3.1 지원
- DRAM, CPU, SB 전압 멀티 조절

지원 CD	<ul style="list-style-type: none"> • 드라이버 , 유틸리티 , 안티바이러스 소프트웨어 (시험판) , Google Chrome Browser 및 Toolbar, Start8 (30일 시험판)
하드웨어 모니터	<ul style="list-style-type: none"> • CPU 온도 감지 • 마더보드 온도 감지 • CPU 회전 속도계 : 샤프 (케이스) 팬 회전 속도계 • 샤프 회전 속도계 : 샤프 (케이스) 팬 회전 속도계 • CPU/ 샤프 저소음 팬 • CPU/ 샤프 팬 멀티스피드 컨트롤 • 전압 감시 기능 : +12V,+5V,+3.3V,Vcore
OS	<ul style="list-style-type: none"> • 마이크로 소프트 Windows® 8.1 32 비트 /8.1 64 비트 /8 32 비트 /8 64 비트 /7 32 비트 /7 64 비트
인증서	<ul style="list-style-type: none"> • FCC, CE, WHQL • ErP/EuP 지원 (ErP/EuP 지원 전원 공급기가 요구됨)

* 상세한 제품정보는 당사의 웹사이트를 방문할수있습니다 .
<http://www.asrock.com>

1.3 점퍼 셋팅

그림은 점퍼를 어떻게 셋업 하는지를 보여줍니다 .
 점퍼 캡이 핀 위에 있을 때 , 점퍼는 “쇼트” 입니다 .
 점퍼 캡이 핀 위에 없을 때 점퍼는 “오픈” 입니다 .
 그림은 3 개의 핀 중 1-2번 핀이 “쇼트” 임을
 보여주는 것이며 , 점퍼 캡이 이 두 핀 위에 있음을
 보여주는 것입니다 .

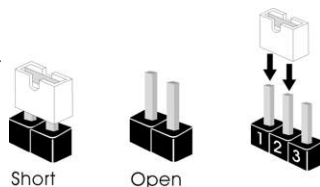

점퍼 세팅

CMOS 초기화

(CLRCMOS1, 3 핀 점퍼)

(1 페이지, 8 번 항목 참조)



참고 : CLRCMOS1 을 사용하여 CMOS 에 들어 있는 데이터를 삭제할 수 있습니다 .
 시스템 매개변수를 삭제하고 기본 설정으로 복원하려면 , 컴퓨터를 끄고 전원
 공급장치에서 플러그를 뽑으십시오 . 15 초를 기다린 다음 점퍼 캡을 사용하여
 CLRCMOS1 의 핀 2 와 핀 3 을 5 초 동안 단락하십시오 . 그러나 BIOS 업데이트
 직후에는 CMOS 를 삭제하지 마십시오 . BIOS 를 업데이트하자마자 CMOS 를
 삭제해야 하는 경우 먼저 시스템을 부팅하고 CMOS 를 종료하고 삭제 작업을 해
 야 합니다 . CMOS 배터리를 제거할 경우에만 암호, 날짜, 시간, 사용자 기본 프
 로파일 , 1394 GUID, MAC 주소가 삭제됩니다 .

USB 전원 점프

(3- 핀 USB01_PWR1)

(1 페이지, 24 번 항목 참조)



참고 : USB 전원 점프는 특히 LED 키보드 / 마우스를 사용하는 사용자를 위한 것
 입니다 . (USB01 포트에 대해서만)

핀 1-2 shorted (기본):

안정된 전압과 고전류가 LED 키보드 / 마우스에 공급됩니다 .

PC 전원이 꺼지면 키보드 / 마우스 조명이 꺼집니다 .

핀 2-3 shorted:

+5VSB 전압이 LED 키보드 / 마우스에 공급됩니다 .

키보드 / 마우스의 절전 기능을 활성화합니다 .

PC 가 대기 모드에 있을 경우 키보드 / 마우스 조명이 켜집니다 .

1.4 온보드 헤더 및 커넥터



주의 !

이 콘넥터는 점퍼가 아닙니다. 이 콘넥터 위에 점퍼 램을 사용하지마세요 . 콘넥터에 점퍼 램을 설치하면 마더보드가 영구적으로 손상됩니다 !

시리얼 ATA2 커넥터

- (SATA_1: 1 페이지, 15 번 항목 참조)
- (SATA_2: 1 페이지, 16 번 항목 참조)
- (SATA_3: 1 페이지, 14 번 항목 참조)
- (SATA_4: 1 페이지, 13 번 항목 참조)
- (SATA_5: 1 페이지, 12 번 항목 참조)
- (SATA_6: 1 페이지, 11 번 항목 참조)

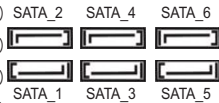

6 개의 시리얼 ATA2

(SATA2) 커넥터는 내부 저장 장치용 SATA 데이터 케이블을 지원합니다 . 커넥터가 내부 기억 장치용 SATA 케이블을 지원합니다 . 현재의 SATA2 인터페이스는 최고 3.0 Gb/s의 데이터 전송 속도를 지원합니다 .

USB 2.0 헤더

- (9 핀 USB45)
- (1 페이지, 17 번 항목 참조)
- (9 핀 USB67)
- (1 페이지, 18 번 항목 참조)

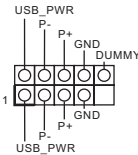

본 머더보드에는 I/O 패널에 있는 6 개의 기본 USB 2.0 포트 외에도 USB 2.0 헤더가 2 개 있습니다 . 각각의 USB 2.0 헤더는 2 개의 USB 2.0 포트를 지원할 수 있습니다 .

전면부 오디오 콘넥터

- (9 핀 HD_AUDIO1)
- (1 페이지, 21 번 항목 참조)

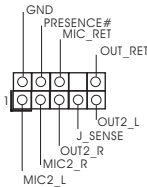

이 콘넥터는 오디오 장치를 편리하게 조절하고 연결할 수 있는 전면 오디오 인터페이스입니다 .



1. High Definition Audio(고음질 오디오)는 잭 센스 기능을 지원하나, 제대로 작동하려면 새시의 패널 와이어가 HAD 를 지원해야 합니다 . 이 설명서 및 새시 설명서의 지침 을 따라 시스템을 설치하십시오 .
2. AC'97 오디오 패널을 사용하는 경우, 이를 아래와 같이 프린트 패널의 오디오헤더에 설치하십시오 .
 - A. Mic_IN (MIC) 을 MIC2_L 에 연결합니다 .
 - B. Audio_R (RIN) 을 OUT2_R 에 연결하고 , Audio_L (LIN) 을 OUT2_L 에 연결합니다 .
 - C. Ground (GND) 을 Ground (GND) 에 연결합니다 .
 - D. MIC_RET 및 OUT_RET 는 HD 오디오 패널 전용입니다 . 이들을 AC'97 오디오 패널에 연결 하지 않아도 됩니다 .

- E. 앞면 마이크 작동 .
 Windows® 8.1 / 8.1 64 비트 / 8 / 8 64 비트 / 7 / 7 64 비트 / XP / XP 64 비트 OS 의 경우 :
 Realtek 제어판에서 “FrontMic” (앞면 마이크) 로 가서
 “Recording Volume” (리코딩 볼륨) 을 조정합니다 .

시스템 콘넥터

(9 핀 PANEL1)

(1 페이지 , 10 번 항목 참조)

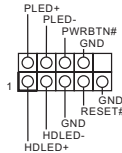

이 콘넥터는 시스템 전면 패널 기능을 지원하기 위한 것입니다 .



새시의 전원 스위치, 리셋 스위치, 시스템 상태 표시등을 아래의 핀 할당에 따라 이헤더에 연결합니다 . 케이블을 연결하기 전에 양극 핀과 음극 핀을 기록합니다 .

PWRBTN(전원 스위치):

새시 전면 패널의 전원 스위치에 연결합니다 . 전원 스위치를 이용해 시스템을 끄는방법을 구성할 수 있습니다 .

RESET(리셋 스위치):

새시 전면 패널의 리셋 스위치에 연결합니다 . 컴퓨터가 정지하고 정상적 재시작을수행하지 못할 경우 리셋 스위치를 눌러 컴퓨터를 재시작합니다 .

PLED(시스템 전원 LED):

새시 전면 패널의 전원 상태 표시등에 연결합니다 . 시스템이 작동하고 있을 때는 LED 가 켜져 있습니다 . 시스템이 S1 대기 상태에 있을 때는 LED 가 계속 깜박입니다 . 시스템이 S3/S4 대기 상태 또는 전원 꺼짐 (S5) 상태에 있을 때는 LED 가 꺼져 있습니다 .

HDLED(하드 드라이브 동작 LED):

새시 전면 패널의 하드 드라이브 동작 LED 에 연결합니다 . 하드 드라이브가 데이터를 읽거나 쓰고 있을 때 LED 가 켜져 있습니다 .

전면 패널 디자인은 새시별로 다를 수 있습니다 . 전면 패널 모듈은 주로 전원 스위치, 리셋 스위치, 전원 LED, 하드 드라이브 동작 LED, 스피커 등으로 구성되어 있습니다 . 새시 전면 패널 모듈을 이 헤더에 연결할 때 와이어 할당과 핀 할당이 정확히 일치하는지 확인합니다 .

새시 스피커 헤더

(4 핀 SPEAKER 1)

(1 페이지 , 9 번 항목 참조)



새시 스피커를 이 헤더에 연결하십시오 .

새시 및 전원 팬 커넥터
(4 핀 CHA_FAN1)
(1 페이지, 7 번 항목 참조)

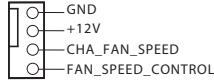

팬 케이블을 팬 커넥터에 연결
하
고 접지 핀에는 검은색 전선을
연결하십시오 .

(3 핀 CHA_FAN2)
(1 페이지, 23 번 항목 참조)

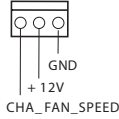

(3 핀 PWR_FAN1)
(1 페이지, 2 번 항목 참조)

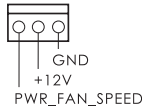

CPU 팬 커넥터
(4 핀 CPU_FAN1)
(1 페이지, 3 번 항목 참조)

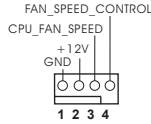

CPU 팬 케이블을 이 커넥터에
연결하고 흑색 선을 접지 핀에
맞추십시오 .



본 머더보드가 4 핀 CPU 팬 (저소음 팬) 지원을 제공하기는 하지만 팬
속도 제어기능없이도 3 핀 CPU 팬을 성공적으로 작동할 수 있습니다 .
본 머더보드의 CPU 팬 커넥터에 3 핀 CPU 팬을 연결하려면 1-3 번 핀에
연결하십시오 .

1-3 번 핀에 연결됨 ←

3 핀 팬 설치



(3 핀 CPU_FAN2)
(1 페이지, 4 번 항목 참조)

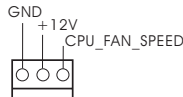

ATX 전원 헤더
(24 핀 ATXPWR1)
(1 페이지, 6 번 항목 참조)

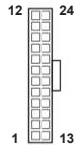

ATX 전원 공급기를 이 헤더에
연결하십시오 .



이 마더보드는 24 핀 ATX 전원 커넥터를 제공하지만, 종래의 20 핀 ATX 전원 공급장치를 사용해도 작동이 가능합니다. 20 핀 ATX 전원 공급장치를 사용하려면, Pin 1 과 Pin 13 으로 전원공급장치를 연결하십시오.



20 핀 ATX 전원 공급장치 설치

ATX 12V 파워 콘넥터

(8 핀 ATX12V1)

(1 페이지, 1 번 항목 참조)

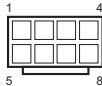

ATX 12V 플러그가 달린 전원공급장치를 이 커넥터에 연결해야 충분한 전력을 공급할 수 있습니다. 그렇지 않을 경우 전원을 켤 수 없습니다.



비록 본 마더보드는 8- 핀 ATX 12V 전원 연결기를 제공하지만 이것은 여전히 작업할 수 있습니다. 만약 전통적인 4- 핀 ATX 12V 전원공급을 채용하여 4- 핀 ATX 전력을 사용하는 경우, 반드시 전원 공급을 핀 1 과 핀 5 에 전원공급을 삽입해야 합니다.

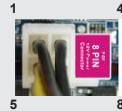

4- 핀 ATX 12V 전원공급장치

PCIe 전원 커넥터

(4- 핀 PCIe_PWR1)

(1 페이지, 22 번 항목 참조)



3 개 이상의 그래픽 카드를 설치한 경우 4- 핀 몰렉스 전원 케이블을 이 커넥터에 연결하십시오.

프린트 포트 헤더

(25 핀 LPT1)

트

(1 페이지, 20 번 항목 참조)

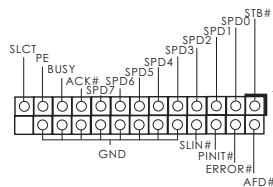

이것은 프린터 장치를 편리하게 연결할 수 있도록 해주는 프린트 케이블용 인터페이스입니다.

TPM 헤더

(17 핀 TPMS1)

(1 페이지, 19 번 회로 참조)

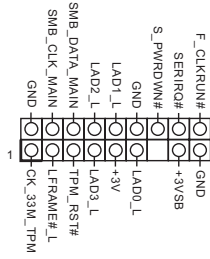

이 커넥터는 키, 디지털 인증서, 암호 및 데이터를 안전하게 보관할 수 있는 TPM(Trusted Platform Module) 시스템을 지원합니다. TPM 시스템은 네트워크 보안을 강화하고, 디지털 신원을 보호하며 플랫폼 무결성을 유지합니다.

1、はじめに

ASRock **FM2A58M+ BTC** マザーボードをお買い上げいただきありがとうございます。本製品は、弊社の厳しい品質管理の下で製作されたマザーボードです。本製品は、弊社の品質と耐久性の両立という目標に適合した堅牢な設計により優れた性能を実現します。このクイックインストールガイドには、マザーボードの説明および段階的に説明したインストールの手引きが含まれています。マザーボードに関するさらに詳しい情報は、「サポート CD」のユーザーマニュアルを参照してください。



マザーボードの仕様およびBIOSソフトウェアは、アップデートされることがありますので、マニュアルの内容は、予告なしに変更されることがあります。本マニュアルに変更があった場合は、弊社のウェブサイトに通告なしに最新版のマニュアルが掲載されます。最新のVGAカードおよびCPUサポートリストもウェブサイトでご覧になれます。ASRock社ウェブサイト：
<http://www.asrock.com>

このマザーボードに関連する技術サポートが必要な場合、当社のWebサイトにアクセスし、使用しているモデルについての特定情報を見つけてください。 www.asrock.com/support/index.asp

1.1 パッケージ内容

ASRock **FM2A58M+ BTC** マザーボード (ATX フォームファクター)

ASRock **FM2A58M+ BTC** クイックインストールガイド

ASRock **FM2A58M+ BTC** サポート CD

2 x シリアル ATA (SATA) データケーブル (オプション)

1 x I/O パネルシールド

1.2 仕様

- プラットフォーム
- ・ マイクロ ATX フォームファクター
 - ・ 全ソリッド・キャパシター設計
 - ・ 高密度ガラス繊維 PCB

- CPU
- ・ Socket FM2+ 95W / FM2 100W プロセッサのサポート

- エッセツト
- ・ AMD A58 FCH (Bolton-D2)
 - ・ 4 + 2 電源位相設計

- メモリー
- ・ デュアルチャンネル DDR3 メモリーテクノロジー
 - ・ DDR3 DIMM スロット x 2
 - ・ DDR3 1866/1600/1333/1066 non-ECC, un-buffered メモリーに対応
 - ・ システムメモリの最大容量：32GB
 - ・ Intel® Extreme Memory Profile (XMP)1.3/1.2 をサポート
 - ・ AMD Memory Profile (AMP) をサポート
 - ・ DIMM スロットの 15 μ 金製接点

- 拡張スロット
- ・ 1 x PCI Express 3.0 x16 スロット (PCIe1: x16 モード)
 - ・ * PCIe 3.0 は FM2+ CPU でのみサポートされます。FM2 CPU では、PCIe 2.0 のみをサポートします。
 - ・ 3 x PCI Express 2.0 x1 スロット
 - ・ VGA PCI-E スロット (PCIe1) の 15 μ 金製接点

- グラフィック
- ・ A シリーズ APU に統合された AMD Radeon™ R7/R5 シリーズグラフィックス
 - ・ FM2+ CPU を搭載した DirectX 11.1、Pixel Shader 5.0。FM2 CPU を搭載した DirectX 11、Pixel Shader 5.0。
 - ・ 最大の共有メモリ 2GB
 - ・ デュアル VGA 出力：独立型ディスプレイコントローラによる DVI-D および D-Sub ポートサポート
 - ・ 2560x1600 @ 60Hz の最大解像度で Dual-link DVI-D をサポート
 - ・ 1920x1200 @ 60Hz の最大解像度で D-Sub をサポート
 - ・ AMD Steady Video™ 2.0 のサポート：家庭 / オンラインビデオの自動ジッター低減用の新しいビデオポストの処理機能
 - ・ HDCP 機能、DVI-D ポートをサポート
 - ・ 1080p Blu-ray (BD) / HD-DVD 再生サポート、DVI-D ポートをサポート

- オーディオ
- ・ 5.1 CH HD オーディオ (Realtek ALC662 オーディオ Codec)
 - ・ サージ保護 (ASRock フルスパイク保護) をサポートします
 - ・ TI® NE5532 (最大 600 Ω のプレミアムヘッドセットアンプをサポート) (背面 I/O のライン出力のみ)

- LAN
- ・ PCIe x1 Gigabit LAN 10/100/1000 Mb/s
 - ・ Realtek RTL8111GR
 - ・ ウェイクオン WAN をサポートします
 - ・ Wake-On-LAN をサポート
 - ・ 雷 /ESD 保護 (ASRock フルスパイク保護) をサポートします
 - ・ LAN ケーブル検出をサポート
 - ・ Energy Efficient Ethernet 802.3az をサポート
 - ・ PXE をサポート

- リアパネル I/O
- ・ PS/2 マウスポート x 1
 - ・ PS/2 キーボードポート x 1
 - ・ D-Sub ポート x 1
 - ・ DVI-D ポート x 1
 - ・ Ready-to-Use USB 2.0 ポート x 6 (ESD 保護 (ASRock フルスパイク保護) をサポートします)
 - ・ LED (ACT/LINK LED および SPEED LED) 付き RJ-45 LAN ポート x 1
 - ・ オーディオジャック : 入力、前部スピーカー、マイク入力

- ストレージ
- ・ 6 x SATA2 3.0Gb/秒 コネクタが、RAID (RAID 0、RAID 1 および RAID 10)、NCQ、AHCI および “Hot Plug” (ホットプラグ) 機能をサポート

- コネクタ
- ・ プリントポートヘッダ x 1
 - ・ 1 x TPM ヘッダ
 - ・ CPU ファンコネクタ x 2 (4 ピン x 1、3 ピン x 1)
 - ・ シャーシファンコネクタ x 2 (4 ピン x 1、3 ピン x 1)
 - ・ 電源ファンコネクタ x 1 (3 ピン)
 - ・ 1 x 24 ピン ATX 電源コネクタ
 - ・ 1 x 8 ピン 12V 電源コネクタ
 - ・ 1 x PCIe 電源コネクタ
 - ・ 1 x フロントパネルオーディオコネクタ
 - ・ 1 x USB 電源ジャンパー (ウルトラ USB パワー)

- ・ USB 2.0 ヘッダー (USB 2.0 用 4 ポートをサポート)
x 2 (ESD 保護 (ASRock フルスバイク保護) をサポート
します)

BIOS 関連 機能

- ・ 64Mb AMI UEFI Legal BIOS (GUI サポート)
- ・ プラグ&プレイをサポート
- ・ ACPI 1.1 準拠ウェイクアップイベント
- ・ jumperfree モードサポート
- ・ SMBIOS 2.3.1 サポート
- ・ DRAM、CPU、SB ブリッジ電圧

サポート CD

- ・ ドライバー、ユーティリティ、アンチウイルスソフトウ
ェアハードウェア (体験版)、Google Chrome Browser
および Toolbar、Start8 (30 日トライアル版)

モニタ

- ・ CPU 温度検知
- ・ マザーボード温度検知
- ・ CPU ファンタコメータ
- ・ シャーシファンタコメータ
- ・ CPU/ マザーボード静音ファン
- ・ CPU/ シャーシファンマルチ速度制御
- ・ 電源モニター : +12V, +5V, +3.3V, Vcore

OS

- ・ Microsoft® Windows® 8.1 32-bit / 8.1 64-bit / 8
32-bit / 8 64-bit / 7 32-bit / 7 64-bit / XP 32-
bit / XP 64-bit

認証

- ・ FCC, CE, Microsoft® WHQL 認証済み
- ・ ErP/EuP 対応 (ErP/EuP 対応の電源装置が必要です)

* 製品の詳細については、<http://www.asrock.com> を御覧なさい。

1.3 ジャンパ設定

右の図はジャンパがどのように設定されているかを示します。ジャンパキャップがピンに置かれている場合、ジャンパは“ショート”になります。ジャンパキャップがピンに置かれていない場合、ジャンパは“オープン”になります。右の図で、3ピンジャンパで、1-2ピンを“ショート”の場合、これらの2つのピンにジャンパキャップを置きます。

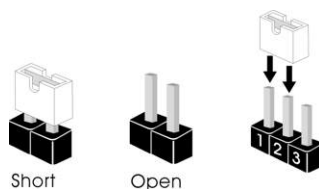

ジャンパ	設定	説明
CMOSの消去ジャンパ (CLR_CMOS1) (ページ2アイテム8参照)	 デフォルト設定	 CMOSの消去

注： CLR_CMOS1により、CMOSのデータをクリアできます。システムパラメータをクリアしデフォルト設定にリセットするには、コンピュータの電源をオフにし、電源装置から電源コードを抜いてください。15秒待つてから、ジャンパキャップを使用してCLR_CMOS1のピン2とピン3を5秒間ショートしてください。ただし、BIOS更新の後すぐにはCMOSをクリアしないでください。BIOSの更新の終了後直ちにCMOSをクリアする必要がある場合、まずシステムを起動してからシャットダウンし、その後クリアCMOSアクションを実行する必要があります。パスワード、日付、時刻、ユーザーデフォルトのプロファイルを忘れずにメモしてください。1394 GUIDとMACアドレスは、CMOSバッテリーを取り外した場合のみ消去されます。

ジャンパ (3-pin USB01_PWR1) (ページ1アイテム24参照)	 +5V (デフォルト)	 +5VSB
--	-----------------	-----------

注記：

USB電源ジャンパーは、LEDキーボードまたはマウスを使用するユーザー専用で作られています。(USB01ポート用のみ)

ピン1-2 (短絡) (デフォルト)：

安定した電圧と高い電流が、LEDキーボード/マウスに対して供給されます。

PCの電源がオフのとき、キーボードまたはマウスのバックライトはオフになります。

ピン2-3 (短絡)：

+5VSB電圧が、LEDキーボード/マウスに対して供給されます。

キーボードまたはマウスのウェイクアップ機能を有効にします。

PCの電源がスタンバイモードのとき、キーボードまたはマウスのバックライトはオンになります。

1.4 オンボードのヘッダとコネクタ類



オンボードのヘッダとコネクタ類はジャンパではありません。それらのヘッダやコネクタにジャンパキャップをかぶせないでください。ヘッダやコネクタにジャンパキャップをかぶせると、マザーボードに深刻な影響を与える場合があります。

シリアル ATA2 コネクタ

SATA_1: ページ 1, アイテム 15 を参照
SATA_2: ページ 1, アイテム 16 を参照
SATA_3: ページ 1, アイテム 14 を参照
SATA_4: ページ 1, アイテム 13 を参照
SATA_5: ページ 1, アイテム 12 を参照
SATA_6: ページ 1, アイテム 11 を参照



これら 6 本のシリアル ATA2 (SATA2) コネクタは内蔵ストレージデバイスに使用する SATA データケーブルに対応しています。現在の SATA2 インタフェースの最大データ転送速度は 3.0 Gb/s です。

USB 2.0 ヘッダ

(9 ピン USB45)
ページ 1, アイテム 17 を参照
(9 ピン USB67)
ページ 1, アイテム 18 を参照

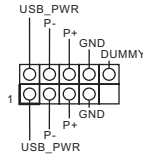

I/O パネルには、デフォルトの 6 つの USB 2.0 ポート以外に、このマザーボードに 2 つの USB 2.0 ヘッダが搭載されています。それぞれの USB 2.0 ヘッダは 2 つの USB 2.0 ポートをサポートできます。

フロントオーディオパネルコネクタ

(9 ピン HD_AUD101)
ページ 1, アイテム 21 を参照

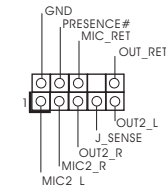

このコネクタは、オーディオ機器との便利な接続とコントロールを可能にするフロントオーディオパネルのためのインターフェイスです。



1. ハイディフィニションオーディオはジャックセンシングをサポートしますが、正しく機能するためにシャーシのパネルワイヤが HAD をサポートする必要があります。このマニュアルとシャーシのマニュアルの指示に従って、システムを取り付けてください。
2. AC' 97 オーディオパネルを使用する場合、次のように前面パネルのオーディオヘッダに取り付けてください。
 - A. Mic_IN (MIC) を MIC2_L に接続します。
 - B. Audio_R (RIN) を OUT2_R に、Audio_L (LIN) を OUT2_L に接続します。
 - C. Ground (GND) を Ground (GND) に接続します。
 - D. MIC_RET と OUT_RET はオーディオパネル専用です。AC' 97 オーディオパネルに接続する必要はありません。

E. フロントマイクを有効化するには。

Windows® 8.1 / 8.1 64-bit / 8 / 8 64-bit / 7 / 7 64-bit/ XP / XP 64-bit OS の場合 :Realtek コントロールパネルから “FrontMic” (フロントマイク) タブを開きます。“Recording Volume”(録音音量) を調整します。

システムパネルコネクタ
(9 ピン PANEL1)

ページ 1, アイテム 10 を参照

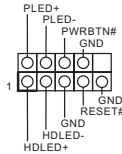

このコネクタは数種類のシステムフロントパネルの機能を提供しフロントパネルの機能を提供します。



シャーシに付いている電源スイッチ、リセットスイッチ、システムステータスインジケータを下記のピン割り当て指示に従ってこのヘッダに接続します。ケーブルを接続する前にピンの正負極性にご注意ください。

PWRBTN (電源スイッチ) :

前面パネルに付いている電源スイッチに接続します。電源スイッチによるシステム電源オフ方法を設定して変更することも可能です。

RESET (リセットスイッチ) :

シャーシの前面パネルに付いているリセットスイッチに接続します。コンピュータがフリーズし、正常な再起動をしない場合は、リセットスイッチを押してコンピュータを再起動します。

PLED (システム電源 LED) :

シャーシの前面パネルに付いている電源ステータスインジケータに接続します。LED は、システムが動作しているときに点灯します。LED はシステムが S3 スリープ状態のときに点滅します。システムが S4 スリープ状態になるか、電源オフ (S5) になると、LED は消灯します。

HDLED (ハードドライブアクティビティ LED) :

シャーシの前面パネルに付いているハードドライブアクティビティ LED に接続します。LED は、ハードドライブがデータの読み込みまたは書き込み動作をしているときに点灯します。

前面パネルのデザインはシャーシによって異なります。前面パネルモジュールは、主に電源スイッチ、リセットスイッチ、電源 LED、ハードドライブアクティビティ LED、スピーカーなどから構成されています。シャーシの前面パネルモジュールをこのヘッダに接続する際は、ワイヤとピンの割り当てが正しく対応していることを確認してください。

シャーシスピーカーヘッダ
(4ピン SPEAKER1)
ページ1, アイテム9を参照

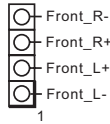

シャーシのスピーカーとこのヘッダを接続してください。

シャーシおよび電源ファンコネクタ
(4ピン CHA_FAN1)
ページ1, アイテム7を参照

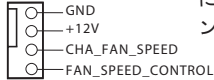

ファンケーブルをファンコネクタに接続し、黒いワイヤをアースピンに合わせてください。

(3ピン CHA_FAN2)
ページ1, アイテム23を参照

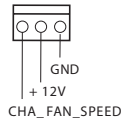

(3ピン PWR_FAN1)
ページ1, アイテム2を参照

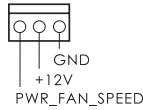

CPU ファンコネクタ
(4ピン CPU_FAN1)
ページ1, アイテム3を参照

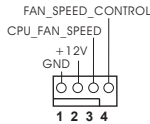

このコネクタにはCPUファンケーブルを接続します。黒いコードはアースピンに接続してください。黒いコードはアースピンに接続してください。



このマザーボードでは4ピンCPUファン(クワイエットファン)がサポートされていますが、ファン速度コントロール機能がない場合でも、3ピンCPUファンは正常に作動します。3ピンCPUファンをこのマザーボードのCPUファンコネクタに接続しようとしている場合、ピン1-3に接続してください。

接続されたピン1-3 ←
3ピンファンのインストール



(3ピン CPU_FAN2)
ページ1, アイテム4を参照

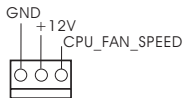

ATX パワーコネクタ

(24 ピン ATXPWR1)

ページ 1, アイテム 6 を参照

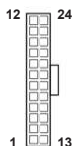

ATX 電源コネクタを接続します。



このマザーボードには 24 ピン ATX 電源コネクタが装備されており、従来の 20 ピン ATX 電源装置を採用している場合でも作動します。20 ピン ATX 電源を使用するには、ピン 1 およびピン 13 と共に電源装置にプラグを差し込みます。

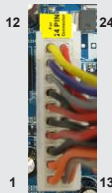

20 ピン ATX 電源装置の取り付け

ATX 12V コネクタ

(8 ピン ATX12V1)

ページ 1, アイテム 1 を参照

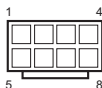

このコネクタには CPU に Vcore

電源を供給できるように、ATX 12V プラグを備えたサワーサプライを接続する必要があることに注意してください。接続に問題があると、電源は正しく供給されません。



このマザーボードで 8-pin ATX 12V 電源コネクタが提供されたが、従来の 4-pin ATX12V 電源でも動作できます。4-pin ATX 電源を使用する場合、電源を Pin 1 と Pin 5 とともに差し込んでください。



4-Pin ATX 12V 電源の取り付け

PCIe 電源コネクタ

(4 ピン PCIe_PWR1)

ページ 1, アイテム 22 を参照



3 以上のグラフィックスカードがインストールされている場合はモレックス製 4 ピン電源ケーブルをこのコネクタに接続してください。

プリントポートヘッダ

(25 ピン LPT1)

ページ 1, アイテム 20 を参照

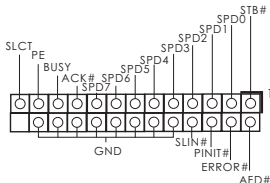

これはプリントポートケーブル用のインターフェイスで、プリンタデバイスの接続を可能にします。

TPM ヘッダー
 (17 ピン TPMS1)
 ページ 1, アイテム 19 を参照

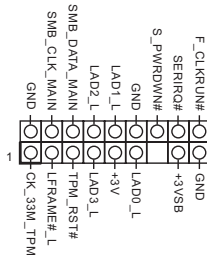

このコネクタはトラステッドプラットフォームモジュール (TPM) システムをサポートし、鍵、デジタル証明書、パスワード、データを安全に保管することができます。 TPM システムはまた、ネットワークセキュリティを高め、デジタル証明書を保護し、プラットフォームの完全性を保証します。

1. 主板简介

谢谢你采用了华擎 **FM2A58M+ BTC** 主板，本主板由华擎严格制造，质量可靠，稳定性好，能够获得卓越的性能。本安装指南介绍了安装主板的步骤。更加详细的主板信息可参看驱动光盘的用户手册。



由于主板规格和 BIOS 软件将不断升级，本手册之相关内容变更恕不另行通知。请注意华擎网站上公布的升级版本。你也可以在华擎网站找到最新的显卡和 CPU 支持表。

华擎网址: <http://www.asrock.com>

如果您需要与此主板有关的技术支持，请参观我们的网站以了解您使用机种的规格信息。

www.asrock.com/support/index.asp

1.1 包装盒内物品

华擎 **FM2A58M+ BTC** 主板 (ATX 规格)

华擎 **FM2A58M+ BTC** 快速安装指南

华擎 **FM2A58M+ BTC** 支持光盘

两条 Serial ATA(SATA) 数据线 (选配)

一块 I/O 挡板

1.2 主板规格

规格尺寸	<ul style="list-style-type: none"> • Micro ATX 规格 • 全固态电容设计 • 高密度防潮纤维电路板
处理器	<ul style="list-style-type: none"> • 支持 Socket FM2+ 95W / FM2 100W 处理器 • 4 + 2 相 CPU 供电设计
芯片组	<ul style="list-style-type: none"> • AMD A58 FCH (Bolton-D2)
内存	<ul style="list-style-type: none"> • 双通道 DDR3 内存技术 • 2 x DDR3 内存插槽 • 支持 1866/1600/1333/1066 non-ECC, un-buffered 内存 • 系统内存最大容量 :32GB • 支持 Intel® Extreme Memory Profile(XMP)1.3/1.2 • 支持 AMD Memory Profile(AMP) 技术 • 15 μ 特厚镀金插槽
扩充插槽	<ul style="list-style-type: none"> • 1 x PCI Express 3.0 x16 插槽 (PCIe1 x16 模式) *FM2+ CPU 支持 PCIe 3.0, FM2 CPU 只支持 PCIe 2.0. • 3 x PCI Express 2.0 x1 插槽 • 15 μ 特厚镀金插槽 (PCIe1)
显卡	<ul style="list-style-type: none"> • A 系列 APU 上集成 AMD Radeon™ R7/R5 显示核心 • FM2+ 为 DirectX 11、Pixel Shader 5.0; FM2 为 DirectX 11、Pixel Shader 5.0 • 最大共享显示内存 2GB • 双重 VGA 输出选项：通过独立显示控制器提供 DVI-D 和 D-Sub 接口 • 支持 Dual-link DVI-D, 最大分辨率达 2560x1600 @ 60Hz • 支持 D-Sub, 最大分辨率达 1920x1200 @ 60Hz • 支持 AMD Steady Video™ 2.0: 全新视频后处理能力, 可为家庭 / 在线视频提供自动降低抖动的功能 • 支持 HDCP with DVI-D 接口 • 通过 DVI-D 接口支持 1080p 蓝光光盘 (BD) 高清晰播放
音效	<ul style="list-style-type: none"> • 5.1 声道高保真音频 (Realtek ALC662 音频编解码器) • 支持防突波 (ASRock 全防护) • TI NE5532 优质耳放 (支持高达 600 欧姆的耳机) (仅限后 I/O 上的线路输出)

网络

- PCIE x1 千兆网卡 10/100/1000 Mb/s
- Realtek RTL8111GR
- 支持广域网唤醒技术 (Wake-On-WAN)
- 支持网络唤醒功能 (Wake-On-LAN)
- 支持防雷击 / 防 ESD 静电 (ASRock 全防护)
- 支持网线侦测
- 支持 Energy Efficient Ethernet 802.3az
- 支持 PXE
- 支持网众，网维大师，锐起，易游无盘软件

背板 I/O

- 1 x PS/2 鼠标接口
- 1 x PS/2 键盘接口
- 1 x D-Sub 接口
- 1 x DVI-D 接口
- 6 x USB 2.0 接口 (支持全防护)
- 1 个网卡接口 LED 指示灯 (ACT/LINK LED 和 SPEED LED)
- HD 音频插孔：线性书入 / 前置喇叭 / 麦克风

存储

- 6 x SATA2 3.0 Gb/s 接口，支持 RAID (RAID 0, RAID 1 和 RAID 10), NCQ, AHCI 和热插拔

板载接口

- 1 x 打印机端口接口
- 1 x TPM 接针
- 2 x CPU 风扇接口 (1 x 4-pin, 1 x 3-pin)
- 2 x 机箱风扇接口 (1 x 4-pin, 1 x 3-pin)
- 1 x 电源风扇接口 (3-pin)
- 1 x 24 针 ATX 电源接口
- 1 x 8 针 12V 电源接口
- 1 x PCIe 电源接口
- 1 x 前面板音频接口
- 1 x USB 电源跳线 (超稳定 USB 供电)
- 2 x USB 2.0 针状接头 (支持 4 个 USB 2.0 接口) (支持防 ESD 静电 (ASRock 全防护))

BIOS 特性

- 64Mb AMI UEFI Legal BIOS, 支持 GUI
- 支持即插即用 (Plug and Play, PnP)
- ACPI 1.1 电源管理
- 支持唤醒功能
- 支持 jumperfree 免跳线模式
- DRAM、CPU、SB 电压多功能调节器

支持光盘

- 驱动程序，应用软件，Chrome 谷歌浏览器和工具栏，Start8 (30 天试用版)

硬件监控

- CPU 温度侦测
- 主板温度侦测
- CPU 风扇转速计
- 机箱风扇转速计
- CPU/ 机箱静音风扇
- CPU/ 机箱风扇多速控制
- 电压范围：+12V, +5V, +3.3V, 核心电压

操作系统

- Microsoft® Windows® 8.1 32 位元 /8.1 64 位元 /8 32 位元 /8 64 位元 /7 32 位元 /7 64 位元 /XP 32 位元 /XP 64 位元

认证

- FCC, CE, WHQL
- 支持 ErP/EuP (需要同时使用支持 ErP/EuP 的电源供应器)

* 请参阅华擎网站了解详细的产品信息：<http://www.asrock.com>

1.3 跳线设置

插图所示的就是设置跳线的方法。当跳线帽放置在针脚上时，这个跳线就是“短接”。如果针脚上没有放置跳线帽，这个跳线就是“开路”。插图显示了一个 3 针脚的跳线，当跳线帽放置在针脚 1 和针脚 2 之间时就是“短接”。

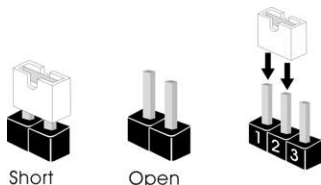

接脚 设定

清除 CMOS

(CLRCMOS1, 3 针脚跳线)
(见第 1 页第 8 项)



注意： CLRCMOS1 允许您清除 CMOS 中的数据。如要清除并将系统参数恢复至默认设置，请关闭计算机，然后从电源插座上拔掉电源线。等待 15 秒后，使用跳线帽将 CLRCMOS1 上的插针 2 和插针 3 短接 5 秒。但是，请勿在更新 BIOS 后立即清除 CMOS。如果需要在更新 BIOS 后立即清除 CMOS，必须在执行 CMOS 清除操作之前，先启动然后关闭系统。请注意，只有取出 CMOS 电池，密码、日期、时间、用户默认配置文件、1394 GUID 和 MAC 地址才会被清除。

电源跳线

(3 针 USB01_PWR1)
(见第 1 页第 24 项)



USB 电源跳线适用于使用 LED 键盘 / 鼠标的用户。（仅适用于 USB01 端口）
针脚 1-2 短接（默认）：

为 LED 键盘 / 鼠标提供稳定的电压和高电流。

PC 关闭时键盘 / 鼠标的背光将为关。

针脚 2-3 短接：

为 LED 键盘 / 鼠标提供 +5VSB 电压。

启用键盘 / 鼠标的唤醒功能。

PC 待机时键盘 / 鼠标的背光将为开。

1.4 板载接头和接口



板载接头和接口不是跳线。切勿将跳线帽放置在这些接头和接口上。将跳线帽放置在接头和接口上将会导致主板的永久性损坏！

Serial ATA2 接口

(SATA_1: 见第 1 页第 15 项)

(SATA_2: 见第 1 页第 16 项)

(SATA_3: 见第 1 页第 14 项)

(SATA_4: 见第 1 页第 13 项)

(SATA_5: 见第 1 页第 12 项)

(SATA_6: 见第 1 页第 11 项)



这里有六组 Serial ATA2

(SATA2) 接口支持 Serial (SATA) 数据线作为内部储存设置。目前 SATA2 界面理论上可提供高达 6.0Gb/s 的数据传输速率。

USB 2.0 扩展接头

(9 针 USB45)

(见第 1 页第 17 项)

(9 针 USB67)

(见第 1 页第 18 项)

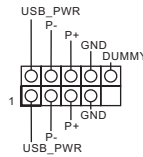

除了位于 I/O 面板的六个默认 USB 2.0 接口之外，这款主板有两组 USB 2.0 接头。这组 USB 2.0 接头可以支持两个 USB 2.0 接口。

前置音频面板接头

(9 针 HD_AUD101)

(见第 1 页第 21 项)

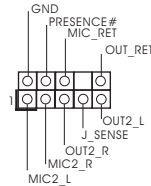

可以方便连接音频设备。



- 高保真音频 (High Definition Audio, HDA) 支持智能音频接口检测功能 (Jack Sensing)，但是机箱面板的连线必须支持 HDA 才能正常使用。请按我们提供的手册和机箱手册上的使用说明安装您的系统。
- 如果您使用 AC' 97 音频面板，请按照下面的步骤将它安装到前面板音频接头：
 - 将 Mic_IN (MIC) 连接到 MIC2_L。
 - 将 Audio_R (RIN) 连接到 OUT2_R，将 Audio_L (LIN) 连接到 OUT2_L。
 - 将 Ground (GND) 连接到 Ground (GND)。
 - MIC_RET 和 OUT_RET 仅用于 HD 音频面板。您不必将它们连接到 AC' 97 音频面板。
 - 开启前置麦克风。
在 Windows® 8.1 / 8.1 64 位元 / 8 / 8 64 位元 / 7 / 7 64 位元 / XP / XP 64 位元操作系统中：
在 Realtek 控制面板中点击” FrontMic”。调节” Recording Volume”。

系统面板接头

(9 针 PANEL1)
(见第 1 页第 10 项)

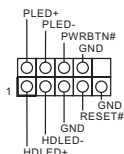

这个接头提供数个系统前面板功能。



根据下面的针脚说明连接机箱上的电源开关、重启按钮与系统状态指示灯到这个排针。根据之前请注意针脚的正负极。

PWRBTN (电源开关) :

连接机箱前面板的电源开关。您可以设置用电源键关闭系统的方式。

RESET (重启开关) :

连接机箱前面板的重启开关。当电脑死机且无法正常重新启动时，可按下重启开关重新启动电脑。

PLED (系统电源指示灯) :

连接机箱前面板的电源状态指示灯。当系统运行时，此指示灯亮起。当系统处于 S1 待机模式时，此指示灯保持闪烁。当系统处于 S3/S4 待机模式或关机 (S5) 模式时，此指示灯熄灭。

HD LED (硬盘活动指示灯) :

连接机箱前面板的硬盘动作指示灯。当硬盘正在读取或写入数据时，此指示灯亮起。

前面板设计因机箱不同而有差异。前面板模块一般由电源开关、重启开关、电源指示灯、硬盘动作指示灯、喇叭等构成。将您的机箱前面板连接到此排针时，请确认连接线与针脚上的说明相对应。

机箱喇叭接头

(4 针 SPEAKER1)
(见第 1 页第 9 项)

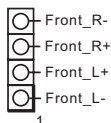

请将机箱喇叭连接到这个接头。

机箱，电源风扇接头

(4 针 CHA_FAN1)
(见第 1 页第 7 项)

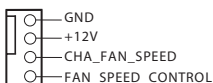

请将风扇连接线接到这个接头，并让黑线与接地的针脚相接。

(3 针 CHA_FAN2)
(见第 1 页第 23 项)

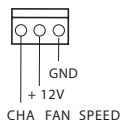

(3 针 PWR_FAN1)
(见第 1 页第 2 项)

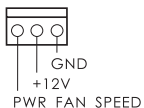

CPU 风扇接头
(4 针 CPU_FAN1)
(见第 1 页第 3 项)

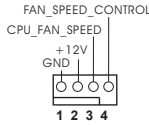

请将 CPU 风扇连接线接到这个接头，并让黑线与接地的针脚相接。



虽然此主板支持 4-Pin CPU 风扇 (Quiet Fan, 静音风扇)，但是没有调速功能的 3-Pin CPU 风扇仍然可以在此主板上正常运行。如果您打算将 3-Pin CPU 风扇连接到此主板的 CPU 风扇接口，请将它连接到 Pin 1-3。

Pin 1-3 连接
3-Pin 风扇的安装



(3 针 CPU_FAN2)
(见第 1 页第 4 项)

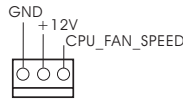

ATX 电源接头
(24 针 ATXPWR1)
(见第 1 页第 6 项)

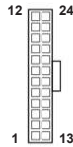

请将 ATX 电源供应器连接到这个接头。



虽然此主板提供 24-pin ATX 电源接口，但是您仍然可以使用传统的 20-pin ATX 电源。为了使用 20-pin ATX 电源，请顺著 Pin 1 和 Pin 13 插上电源接头。

20-Pin ATX 电源安装说明



ATX 12V 接头
(8 针 ATX12V1)
(见第 1 页第 1 项)

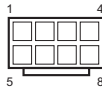

请将一个 ATX 12V 电源供应器接到这个接头。



虽然此主板提供 8-pin ATX 12V 电源接口，但是您仍然可以使用传统的 4-pin ATX 12V 电源。为了使用 4-pin ATX 12V 电源，请顺著 Pin 1 和 Pin 5 插上电源接头。

4-Pin ATX 12V 电源安装说明

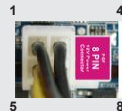

PCIe 电源接口

(4 针 PCIe_PWR1)
(见第 1 页第 22 项)



在安装了三个以上图形卡时，
请将 4 针 molex 电源线连接到此
接口。

打印机端口接针

(25 针 LPT1)
(见第 1 页第 20 项)

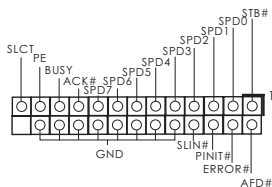

这是一个连接打印机端口的
接口，方便您连接打印机设
备。

TPM 接脚

(17 针 TPMS1)
(见第 1 页第 19 项))

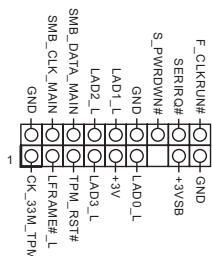

此接口支持 Trusted Platform
Module (信任平台模块, TPM)
系统, 可以安全地存储密钥、数
字证书、密码和数据。TPM 系统
也可以帮助增强网络安全, 保护
数字身份和确保平台完整性。

电子信息产品污染控制标示

依据中国发布的「电子信息产品污染控制管理办法」及 SJ/T 11364-2006「电子信息产品污染控制标示要求」，电子信息产品应进行标示，藉以向消费者揭露产品中含有的有毒有害物质或元素不致发生外泄或突变从而对环境造成污染或对人身、财产造成严重损害的期限。依上述规定，您可于本产品之印刷电路板上看见图一之标示。图一中之数字为产品之环保使用期限。由此可知此主板之环保使用期限为 10 年。



图一

有毒有害物质或元素的名称及含量说明

若您欲了解此产品的有毒有害物质或元素的名称及含量说明，请参照以下表格及说明。

部件名称	有害物质或元素					
	铅 (Pb)	镉 (Cd)	汞 (Hg)	六价铬 (Cr (VI))	多溴联苯 (PBB)	多溴二苯醚 (PBDE)
印刷电路板及电子组件	X	O	O	O	O	O
外部信号连接头及线材	X	O	O	O	O	O

O: 表示该有毒有害物质在该部件所有均质材料中的含量均在 SJ/T 11363-2006 标准规定的限量要求以下。

X: 表示该有毒有害物质至少在该部件的某一均质材料中的含量超出 SJ/T 11363-2006 标准规定的限量要求，然该部件仍符合欧盟指令 2002/95/EC 的规范。

备注：此产品所标示之环保使用年限，系指在一般正常使用状况下。

1. 主機板簡介

謝謝你採用了華擎 **FM2A58M+ BTC** 主機板，本主機板由華擎嚴格製造，品質可靠，穩定性好，能夠獲得卓越的性能。此快速安裝指南包括了主機板介紹和分步驟安裝指導。您可以查看支持光碟裡的使用手冊了解更詳細的資料。



由於主機板規格和 BIOS 軟體將不斷更新，本手冊之相關內容變更恕不另行通知。請留意華擎網站上公布的更新版本。你也可以在華擎網站找到最新的顯示卡和 CPU 支援列表。

華擎網址：<http://www.asrock.com>

如果您需要與此主機板有關的技術支援，請參觀我們的網站以了解您使用機種的規格訊息。

www.asrock.com/support/index.asp

1.1 包裝盒內物品

華擎 **FM2A58M+ BTC** 主機板 (ATX 規格)

華擎 **FM2A58M+ BTC** 快速安裝指南

華擎 **FM2A58M+ BTC** 支援光碟

兩條 Serial ATA(SATA) 數據線 (選配)

一塊 I/O 擋板

1.2 主機板規格

架構	<ul style="list-style-type: none"> • Micro ATX 尺寸 • 全固態電容設計 • 高密度防潮纖維電路板
處理器	<ul style="list-style-type: none"> • 支援插座 FM2+ 95W / FM2 100W 處理器 • 4 + 2 電源相位設計
晶片組	<ul style="list-style-type: none"> • AMD A58 FCH (Bolton-D2)
系統記憶體	<ul style="list-style-type: none"> • 支援雙通道 DDR3 記憶體技術 • 2 個 DDR3 DIMM 插槽 • 支援 DDR3 1866/1600/ 1333/1066 non-ECC、un-buffered 記憶體 • 最高支援 32GB 系統容量 • 支援 Intel® Extreme Memory Profile(XMP)1.3/1.2 • 支援 AMD Memory Profile(AMP) 記憶體模組技術 • 15μ 特厚鍍金插槽
擴充插槽	<ul style="list-style-type: none"> • 1 x PCI Express 3.0 x16 插槽 (PCIe1: x16 模式) * PCIe 3.0 僅支援 FM2+ CPU。使用 FM2 CPU 時，僅支援 PCIe 2.0。 • 2 x PCI Express 2.0 x1 插槽 • 15μ 特厚鍍金插槽 (PCIe1)
內建顯示	<ul style="list-style-type: none"> • A 系列 APU 整合 AMD Radeon™ R7/R5 系列顯示晶片 • FM2+ CPU 採用 DirectX 11.1、Pixel Shader 5.0。FM2 CPU 採用 DirectX 11、Pixel Shader 5.0。 • 最大共享記憶體 2GB • 雙 VGA 輸出：透過獨立顯示控制器提供 DVI-D 和 D-Sub 接口 • 支援 Dual-link DVI-D，最高解析度達 2560x1600 @ 60Hz • 支援 D-Sub，最高解析度達 1920x1200 @ 60Hz • 支援 AMD Steady Video™ 2.0：最新影像後處理能力，可為家庭 / 線上影像提供自動降低手震的功能 • DVI-D 接口支援 HDCP 功能 • DVI-D 接口可播放 1080p 藍光光碟 (BD) / HD-DVD 光碟
音效	<ul style="list-style-type: none"> • 5.1 聲道高清晰音效 (Realtek ALC662 音效編解碼器) • 支援防突波 (ASRock 全防護) • TI® NE5532 (支援最高 600 Ohms 的 Premium Headset Amplifier) (僅限由後側 I/O 輸出線路)

網路功能

- PCIE x1 Gigabit LAN 10/100/1000 Mb/s
- Realtek RTL8111GR
- 支援遠端開機 (Wake-On-WAN)
- 支援網路喚醒 (Wake-On-LAN)
- 支援防雷擊 / 防 ESD 靜電 (ASRock 全防護)
- 支援網路線偵測功能
- 支援 Energy Efficient Ethernet 802.3az
- 支援 PXE

Rear Panel
I/O(後背
板輸入 / 輸
出接口)

- 1 個 PS/2 滑鼠接口
- 1 個 PS/2 鍵盤接口
- 1 個 D-Sub 接口
- 1 個 DVI-D 接口
- 6 個可直接使用的 USB 2.0 接口
(支援全防護)
- 1 個 RJ-45 區域網接口與 LED 指示燈 (ACT/LINK LED 和
SPEED LED)
- 高清晰音效插孔：音效輸入 / 前置喇叭 / 麥克風

儲存裝置

- 6 x SATA2 3.0Gb/s 接頭，支援 RAID (RAID 0, RAID 1
和 RAID 10), NCQ, AHCI 和熱插拔功能

接頭

- 1 x 印表機接針
- 1 x TPM 標頭
- 2 x CPU 風扇接頭 (1 x 4 針, 1 x 3 針)
- 2 x 機箱風扇接頭 (1 x 4 針, 1 x 3 針)
- 1 x 電源風扇接頭 (3 針)
- 1 x 24 針 ATX 電源接頭
- 1 x 8 針 12V 電源接頭
- 1 x PCIe 電源接頭
- 1 x 前置音效接頭
- 1 x USB 電源跳線 (超穩定 USB 供電)
- 2 x USB 2.0 接頭 (可支援 4 個額外的 USB 2.0 接口)
(支援全防護)

BIOS

- 64Mb AMI UEFI Legal BIOS (支援 GUI)
- 支援即插即用 (Plug and Play, PnP)
- ACPI 1.1 電源管理
- 支援喚醒功能
- 支援 jumperfree 免跳線模式
- DRAM、CPU、SB 電壓多功能調節

支援光碟

- 驅動程式、工具軟體、防毒軟體 (試用版本)、Google
Chrome Browser 和 Toolbar、Start8 (30 天試用)

- 支援光碟
- 驅動程式、工具軟體、防毒軟體（試用版本）、Google Chrome Browser 和 Toolbar、Start8（30 天試用）

硬體監控

- CPU 溫度偵測
- 主機板溫度偵測
- CPU 風扇轉速計
- 機箱風扇轉速計
- CPU/ 機箱靜音風扇
- CPU/ 機箱風扇多速控制
- 電壓範圍：+12V, +5V, +3.3V, 核心電壓

操作系統

- Microsoft® Windows® 8.1 32 位元 /8.1 64 位元 /8 32 位元 /8 64 位元 /7 32 位元 /7 64 位元 /XP 32 位元 /XP 64 位元

認證

- FCC, CE, WHQL
- 支援 ErP/EuP（需要同時使用支援 ErP/EuP 的電源供應器）

* 請參閱華擎網站了解詳細的產品訊息：<http://www.asrock.com>

1.3 跳線設置

插圖所示的就是設置跳線的方法。當跳線帽放置在針腳上時，這個跳線就是“短接”。如果針腳上沒有放置跳線帽，這個跳線就是“開路”。插圖顯示了一個3針腳的跳線，當跳線帽放置在針腳1和針腳2之間時就是“短接”。

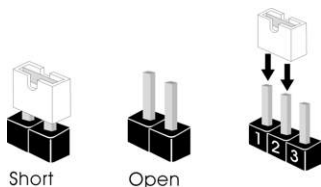

接腳 設定

清除 CMOS

(CLR CMOS, 3 針腳跳線)
(見第 1 頁第 8 項)



註： CLR CMOS 可供您清除 CMOS 中的資料。若要清除及重設系統參數並恢復為預設設定，請先關閉電腦電源，並從電源插座中拔下電源線，等待 15 秒鐘之後，使用跳線帽使 CLR CMOS 的 pin2 及 pin3 短路 5 秒的時間。但請勿於更新 BIOS 後立即清除 CMOS。如需於更新 BIOS 後立即清除 CMOS，您必須先開機再開機，然後再執行 CMOS 清除操作。請注意，只有在移除 CMOS 電池的情況下，密碼、日期、時間、使用者預設設定檔、1394 GUID 及 MAC 位址才會清除。

USB 電源跳線

(3 腳位 USB01_PWR1)
(見第 1 頁第 24 項)

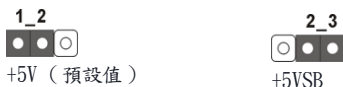

USB 電源跳線專為使用 LED 鍵盤 / 滑鼠的使用者所設計。(僅適用於 USB01 接口)

腳位 1-2 短路 (預設值)：

提供 LED 鍵盤 / 滑鼠穩定的電壓及高電流。

PC 關機時，鍵盤 / 滑鼠的背光將熄滅。

腳位 2-3 短路：

提供 LED 鍵盤 / 滑鼠 +5VSB 電壓。

啟用鍵盤 / 滑鼠的喚醒功能。

PC 處於待命模式時，鍵盤 / 滑鼠的背光將亮起。

1.4 接頭



此類接頭是不用跳線帽連接的，請不要用跳線帽短接這些接頭。
跳線帽不正確的放置將會導致主機板的永久性損壞！

接頭	圖示	說明
Serial ATA2 接口 (SATA_1: 見第 1 頁第 15 項) (SATA_2: 見第 1 頁第 16 項) (SATA_3: 見第 1 頁第 14 項) (SATA_4: 見第 1 頁第 13 項) (SATA_5: 見第 1 頁第 12 項) (SATA_6: 見第 1 頁第 11 項)		這裡有六組 Serial ATA2 (SATA2) 接口支援 SATA 數據線作為內部儲存設置。 目前 SATA2 界面理論上可提供高達 3.0Gb/s 的數據傳輸速率。

USB 2.0 擴充接頭

(9 針 USB45)
(見第 1 頁第 17 項)
(9 針 USB67)
(見第 1 頁第 18 項)

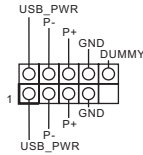

除了位於 I/O 面板的六個 USB 2.0 接口之外，這款主機板有兩組 USB 2.0 接針。每組 USB 2.0 接針可以支援兩個 USB 2.0 接口。

前置音效接頭

(9 針 HD_AUD101)
(見第 1 頁第 21 項)

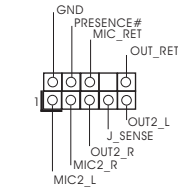

可以方便連接音效設備。



- 高清晰音效 (High Definition Audio, HDA) 支援智能音效接口檢測功能 (Jack Sensing)，但是機箱面板的連線必須支持 HDA 才能正常使用。請按我們提供的手冊和機箱手冊上的使用說明安裝您的系統。
- 如果您使用 AC' 97 音效面板，請按照下面的步驟將它安裝到前面板音效接針：
 - 將 Mic_IN(MIC) 連接到 MIC2_L。
 - 將 Audio_R(RIN) 連接到 OUT2_R，將 Audio_L(LIN) 連接到 OUT2_L。
 - 將 Ground(GND) 連接到 Ground(GND)。
 - MIC_RET 和 OUT_RET 僅用於 HD 音效面板。您不必將它們連接到 AC' 97 音效面板。
 - 開啟前置麥克風。
在 Windows® 8.1 / 8.1 64 位元 / 8 / 8 64 位元 / 7 / 7 64 位元 / XP / XP 64 位元作業系統中：
在 Realtek 控制面板中點選“FrontMic”。調整“Recording Volume”。

系統面板接頭
(9 針 PANEL1)
(見第 1 頁第 10 項)

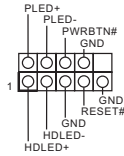

可接各種不同燈，電源開關及重啟鍵等各種連線。



請根據下面的腳位說明連接機箱上的電源開關、重開按鈕與系統狀態指示燈到這個接頭。請先注意針腳的正負極。

PWRBTN(電源開關):

連接機箱前面板的電源開關。您可以設定用電源鍵關閉系統的方式。

RESET(重開開關):

連接機箱前面板的重開開關。當電腦當機且無法正常重新啟動時，可按下重開開關重新啟動電腦。

PLED(系統電源指示燈):

連接機箱前面板的電源狀態指示燈。當系統運行時，此指示燈亮起。當系統處於 S1 待命模式時，此指示燈保持閃爍。當系統處於 S3/S4 待命模式或關機 (S5) 模式時，此指示燈熄滅。

HD LED(硬碟活動指示燈):

連接機箱前面板的硬碟動作指示燈。當硬碟正在讀取或寫入數據時，此指示燈亮起。

前面板設計因機箱不同而有差異。前面板模組一般由電源開關、重開開關、電源指示燈、硬碟活動指示燈、喇叭等構成。將您的機箱前面板连接到此接頭時，請確認連線與針腳上的說明相對應。

機箱喇叭接頭
(4 針 SPEAKER1)
(見第 1 頁第 9 項)

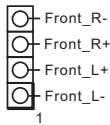

請將機箱喇叭連接到這個接頭。

機箱，電源風扇接頭
(4 針 CHA_FAN1)
(見第 1 頁第 7 項)

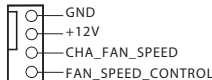

請將風扇連線接到這個接頭，並讓黑線與接地的針腳相接。

(3 針 CHA_FAN2)
(見第 1 頁第 23 項)

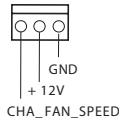

(3 針 PWR_FAN1)
(見第 1 頁第 2 項)

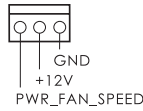

CPU 風扇接頭

(4 針 CPU_FAN1)
(見第 1 頁第 3 項)

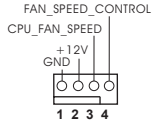

請將 CPU 風扇連接線接到這個接頭，讓黑線與接地的針腳相接。



雖然此主板支持 4-Pin CPU 風扇 (Quiet Fan, 靜音風扇)，但是沒有調速功能的 3-Pin CPU 風扇仍然可以在此主板上正常運行。如果您打算將 3-Pin CPU 風扇連接到此主板的 CPU 風扇接口，請將它連接到 Pin 1-3。

Pin 1-3 連接 ←
3-Pin 風扇的安裝



(3 針 CPU_FAN2)
(見第 1 頁第 4 項)

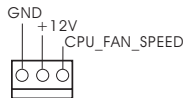

ATX 電源接頭

(24 針 ATXPWR1)
(見第 1 頁第 6 項)

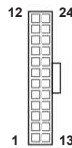

請將 ATX 電源供應器連接到這個接頭。



雖然此主機板提供 24-pin ATX 電源接口，但是您仍然可以使用傳統的 20-pin ATX 電源。為了使用 20-pin ATX 電源，請順著 Pin 1 和 Pin 13 插上電源接頭。

20-Pin ATX 電源安裝說明



ATX 12V 電源接口

(8 針 ATX12V1)
(見第 1 頁第 1 項)

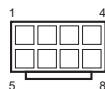

請注意，必需將帶有 ATX 12V 插頭的電源供應器連接到這個插座，這樣就可以提供充足的電力。如果不這樣做，就會導致供電故障。



雖然此主機板提供 8-pin ATX 12V 電源接口，但是您仍然可以使用傳統的 4-pin ATX 12V 電源。為了使用 4-pin ATX 12V 電源，請順著 Pin 1 和 Pin 5 插上電源接頭。

4-Pin ATX 12V 電源安裝說明

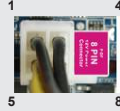

PCIe 電源接頭

(4 腳位 PCIE_PWR1)
(見第 1 頁第 22 項)



安裝三張以上顯示卡時，請將 4 腳位 Molex 電源線接至此接頭。

印表機接針

(25 針 LPT1)
(見第 1 頁第 20 項)

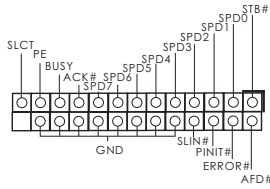

這是一個連接印表機的接口，方便您連接印表機設備。

TPM 標頭

(17-pin TPMS1)
(請參閱第 1 頁，編號 19)

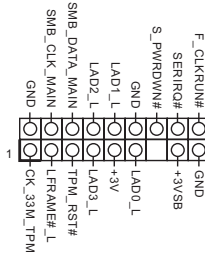

此接頭支援信賴平台模組 (TPM) 系統，可確保儲存金鑰、數位憑證、密碼及資料的安全。TPM 系統也能強化網路安全、保護數位身分並確定平台完整性。

1. Penjelasan

Terimakasih untuk membeli papan induk penghasil kontrol kualitas keras terus-menerus ASRock's yang dapat dipercaya. Dia dapat menyajikan pertunjukan baik dengan bentuknya sesuai dengan janji kualitas dan ketahanan ASRock's. Buku Pedoman Instalasi Cepat ini mengandung pengenalan papan induk dan instalasi langkah-demi-langkah. Informasi lebih terperinci tentang papan induk ini dapat dilihat dalam buku tangan pemakai dalam Support CD.



Karena spesifikasi papan induk dan software BIOS barangkali dapat diperbarui, isi dalam buku pedoman ini akan mengikuti perubahan tanpa peringatan. Dalam kondisi terjadinya modifikasi buku pedoman ini, versi baru akan diperlihatkan dalam website ASRock tanpa peringatan lebih. Anda dapat mendapatkan kartu-kartu yang paling baru dan daftar bantuan CPU pada website ASRock. Website ASRock <http://www.asrock.com>

1.1 Isi Paket

Papan Induk **FM2A58M+ BTC** ASRock (Faktor Form ATX)

Pemimpin Instalasi Cepat **FM2A58M+ BTC** ASRock

Support CD **FM2A58M+ BTC** ASRock

2 x Kabel satu serial Data ATA (SATA) (bebas-pilih)

1 x Satu Pelindung I/O

1.2 Spesifikasi

Podium

- Bentuk dan Ukuran Micro ATX
- Desain All Solid Capacitor
- PCB Struktur Kaca Kepadatan Tinggi

CPU

- Didukung untuk prosesor Socket FM2+ 95W/FM2 100W
- Desain daya 4 + 2 fase

Grup Chip

- AMD A58 FCH (Bolton-D2)

Ingatan

- Teknologi ingatan DDR3 dwisaluran
- 2 x Alur DDR3 DIMM
- Menggunakan DDR3 1866/1600/1333/1066
- Kapasitas paling banyak: 32GB
- Mendukung Intel® Extreme Memory Profile (XMP)1.3/1.2
- Mendukung Teknologi AMD Memory Profile (AMP)
- Kontak Emas 15µ pada slot DIMM

Alur Ekspansi

- 1 x PCI Express 3.0 x16 slots (PCIE1: x16 mode)
- * PCIE 3.0 hanya didukung dengan FM2+ CPU. Dengan FM2 CPU, hanya mendukung PCIE 2.0.
- 3 x PCI Express 2.0 x1 slot
- Kontak Emas 15µ pada slot PCIe VGA (PCIE1)

Diagram

- Grafis seri AMD Radeon™ R7/R5 terintegrasi di APU seri A
- DirectX 11.1, Pixel Shader 5.0 dengan FM2+ CPU. DirectX 11, Pixel Shader 5.0 dengan FM2 CPU.
- Ingatan sama Max. 2GB
- Output VGA Ganda: mendukung port DVI-D dan D-Sub
- Mendukung Dual-link DVI-D dengan resolusi maksimal hingga 2560x1600 @ 60Hz
- Mendukung D-Sub dengan resolusi maksimal hingga 1920x1200 @ 60Hz
- Mendukung AMD Video™ 2.0 Tenang: Baru video pasca

- kemampuan pengolahan untuk pengurangan jitter otomatis pada rumah / online video
- Supports D-Sub with max. resolution up to 1920x1200 @ 60Hz
- Supports AMD Steady Video™ 2.0: New video post processing capability for automatic jitter reduction on home/online video
- Mendukung fungsi HDCP dengan port DVI-D
- Mendukung pemutaran 1080p Blu-ray (BD) / HD-DVD dengan port DVI-D

Audio

- 5.1 CH HD Audio (Realtek ALC662 Audio Codec)
- Mendukung Perlindungan Lonjakan Tegangan (Perlindungan Penuh Lonjakan Tegangan ASRock)
- TI® NE5532 (mendukung Premium Headset Amplifier hingga 600 Ohms) (Line-Out hanya di I/O belakang)

LAN

- PCIE x1 Gigabit LAN 10/100/1000 Mb/s
- Realtek RTL8111GR
- Mendukung Wake-On-WAN
- Menggunakan Wake-On-LAN
- Mendukung Perlindungan Petir/ESD (Perlindungan Penuh Lonjakan Tegangan ASRock)
- Mendukung Deteksi Kabel LAN
- Mendukung Energy Efficient Ethernet 802.3az
- Mendukung PXE

Papan Belakang I/O

- 1 x Port Mouse PS/2
- 1 x Port Keyboard PS/2
- 1 x Port D-Sub
- 1 x Port DVI-D
- 6 x Port USB 2.0 siap-dipakai (Mendukung Perlindungan ESD (Perlindungan Penuh Lonjakan Tegangan ASRock))
- 1 x RJ-45 LAN Port LED (ACT/LINK LED dan SPEED LED)
- HD Audio Jack: Line in / Penyuar Depan / mikropon

Penyimpanan

- 6 x penghubung SATA2 3.0Gb/s, dapat digunakan RAID (RAID 0, RAID 1 dan RAID 10), NCQ, AHCI dan fungsi fungsi “Hot Plug”

Penghubung

- 1 x port header Print
- 1 x Header TPM
- 2 x Penghubung KIPAS CPU (1 x 4 pin, 1 x 3 pin)
- 2 x Penghubung KIPAS casing (1 x 4 pin, 1 x 3 pin)
- 1 x Penghubung KIPAS Power (3 pin)
- Penghubung power 24 pin ATX
- Penghubung power 8 pin 12V
- 1 x Konektor Daya PCIe
- Penghubung audio panel depan
- 1 x Jumper Daya USB (Daya USB Ultra)
- 2 x USB 2.0 header (menggunakan 4 port USB 2.0) (Mendukung Perlindungan ESD (Perlindungan Penuh Lonjakan Tegangan ASRock))

Ciri-ciri BIOS

- 64Mb AMI Legal BIOS
- AMI UEFI Legal BIOS dengan dukungan GUI
- Menggunakan “Plug and Play”
- ACPI 1.1 Compliance Wake Up Events
- Menggunakan jumperfree
- Penyokong AMBIOS 2.3.1
- Penyesuaian berbagai tegangan DRAM, CPU, SB

Sokongan CD

- Penggerak, kegunaan, Software AntiVirus (Versi Coba), Google Chrome Browser dan Toolbar, Start8 (uji coba 30 hari)

Penjaga Hardware

- Perasa Suhu CPU
- Perasa Suhu Casing
- Pengukur Kipas CPU
- Pengukur Kipas casing
- Kipas diam CPU/casing
- Kontrol Multi-Kecepatan Kipas CPU/casing
- Penjagaan voltasi: +12V, +5V, +3.3V, Vcore

OS	<ul style="list-style-type: none">• Microsoft® Windows® 8.1 32-bit / 8.1 64-bit / 8 32-bit / 8 64-bit / 7 32-bit / 7 64-bit / XP 32-bit / XP 64-bit
Sertifikasi	<ul style="list-style-type: none">• FCC, CE, WHQL• ErP/EuP Ready (memerlukan catu daya ErP/EuP ready)

* Untuk informasi rinci, silakan kunjungi website kami: <http://www.asrock.com>

Contact Information

If you need to contact ASRock or want to know more about ASRock, you're welcome to visit ASRock's website at <http://www.asrock.com>; or you may contact your dealer for further information. For technical questions, please submit a support request form at <http://www.asrock.com/support/tsd.asp>

ASRock Incorporation

2F., No.37, Sec. 2, Jhongyang S. Rd., Beitou District,
Taipei City 112, Taiwan (R.O.C.)

ASRock EUROPE B.V.

Bijsterhuizen 3151

6604 LV Wijchen

The Netherlands

Phone: +31-24-345-44-33

Fax: +31-24-345-44-38

ASRock America, Inc.

13848 Magnolia Ave, Chino, CA91710

U.S.A.

Phone: +1-909-590-8308

Fax: +1-909-590-1026